



The Millbrook Power
(Gas Fired Power Station) Order

10.2. Design & Access Statement

Planning Act 2008
The Infrastructure Planning
(Applications: Prescribed Forms and Procedure) Regulations 2009

PINS Reference Number:	EN010068
Document Reference:	10.2
Regulation Number:	5(2)(q)
Author:	Sheppard Robson

Revision	Date	Description
0	October 2017	Submission Version





© Millbrook Power Limited
Drax Power Station
Selby
North Yorkshire
YO8 8PH

<http://www.millbrookpower.co.uk/>

T: 0131 550 3380
E: info@millbrookpower.co.uk

Date of Issue - October 2017





Contents

- 01 Introduction
- 02 Appreciation of Wider Context
- 03 Site Setting
- 04 Design Response
- 05 Indicative Development Proposals
- 06 Summary & Conclusions
- A Appendix



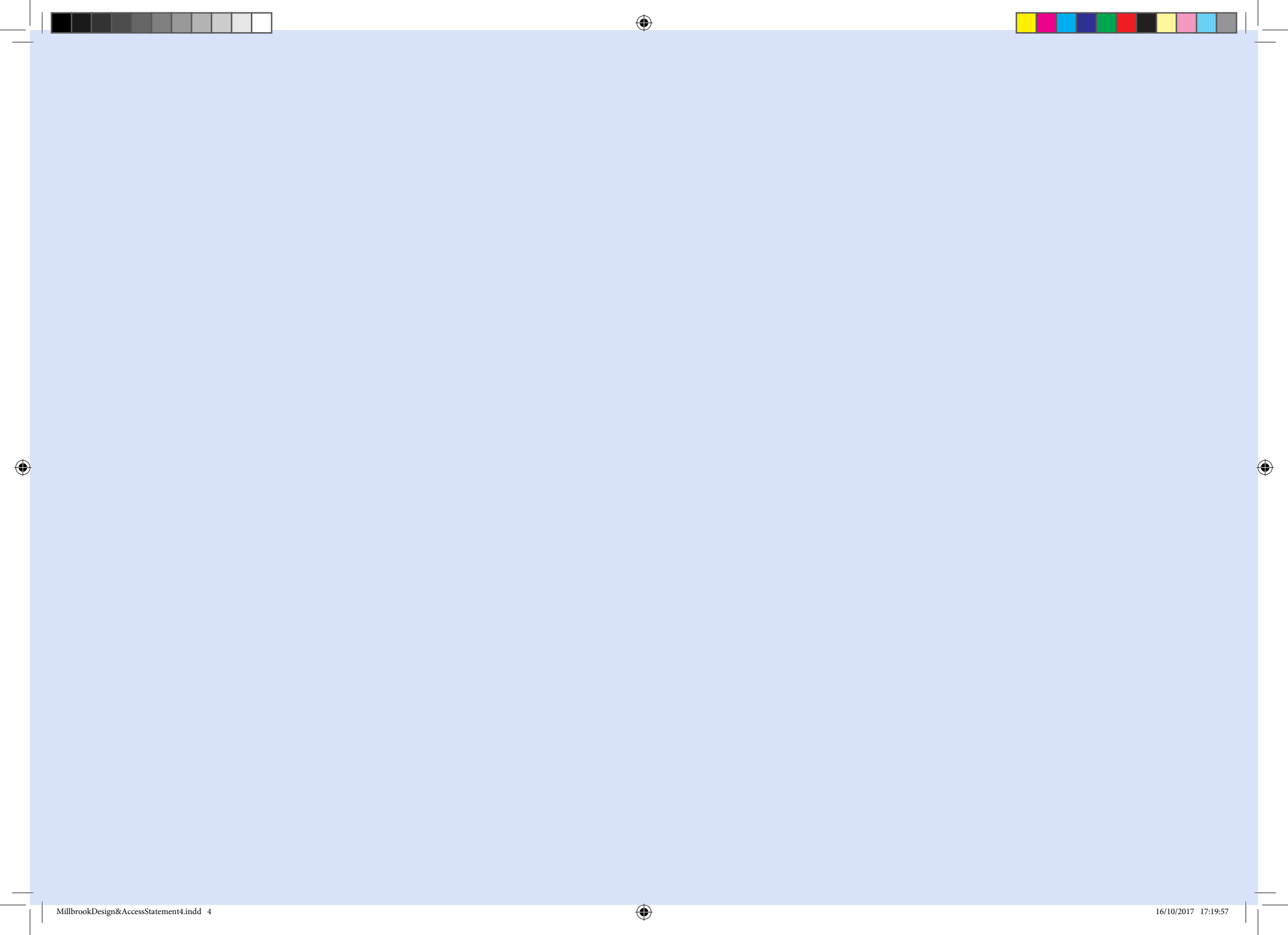



01. Introduction



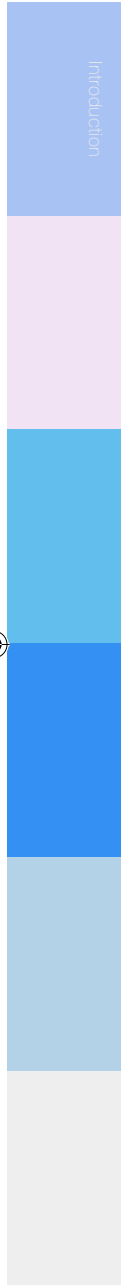

01. Introduction

Introduction

- 1.1. This document is the Design and Access Statement for the Millbrook Power Project. It has been prepared by Sheppard Robson on behalf of Millbrook Power Limited (MPL).
 - A temporary construction compound required during construction only (the 'Laydown Area').
- 1.2. MPL are promoting a new thermal generating station (hereafter referred to as the Power Generation Plant) on land at Rookery South Pit located approximately 2 km to the east of the A421 which connects directly to Junction 13 of the M1 Motorway, approximately 6 km to the south west of the Project Site.
- 1.3. The Power Generation Plant would operate as a Open Cycle Gas Turbine (OCGT) peaking plant and would be designed to provide an electrical output of up to 299 Megawatts (MW). The plant would be fuelled by natural gas.
- 1.4. The three main elements of the Millbrook Power Project comprise: A new Power Generation Plant, a OCGT gas fired power generating station fuelled by natural gas capable of providing up to 299 MW. The Power Generation Plant incorporates:
 - Generating Equipment including one Gas Turbine Generator with one exhaust gas flue stack and Balance of Plant (together referred to as the 'Generating Equipment'), which are located within the 'Generating Equipment Site';
 - A new purpose built access road from Green Lane to the Generating Equipment Site (the 'Access Road');
- 1.5. A new underground gas pipeline connection, approximately 1.8 km in length (the 'Pipeline') to bring natural gas to the Generating Equipment from the National Transmission System (the 'Gas Connection'). The Gas Connection also incorporates an Above Ground Installation (AGI) at the point of connection to the National Transmission System; and
- 1.6. A new electrical connection to export power from the Generating Equipment to the National Grid Electricity Transmission System (NETS) (the 'Electrical Connection'), comprising an underground double circuit Tee-in. This would require one new tower (which will replace an existing tower and be located in the existing Grendon – Sundon transmission route corridor, thereby resulting in no net additional towers). This option would require two SECs, one located on each side of the existing transmission line, and both circuits would then be connected via underground cables approximately 500 m in length to a new substation (the 'Substation').
- 1.7. The Generating Equipment, Access Road and Laydown Area are together known as the 'Power Generation Plant' and are located within the 'Power Generation Plant Site'. The Power Generation Plant Site is approximately 12.5 ha in area.
- 1.8. The Power Generation Plant, Gas Connection, and Electrical Connection, together with all access requirements are referred to as the 'Project'. The land upon which the Project would be developed, or which would be required in order to facilitate the development of the Project, is referred to as the 'Project Site'. The Project Site is approximately 48 ha in area.
- 1.9. A glossary of defined terms is presented in Document Reference 1.4.
- 1.10. **Millbrook Power Limited**
The Applicant for the Project is MPL, an energy development company established for the Project and recently acquired by Drax Group PLC (Drax).
- 1.11. Drax is responsible for generating 7% of the UK's electricity, predominantly via Drax power station in Selby. Drax is one of the UK's largest energy producers and is committed to helping to reduce carbon emissions, displacing more coal off the system and providing additional system support to plug the gaps created by intermittent renewables and boost security of supply.
- 1.12. MPL is committed to the development of assets to support the UK Government's drive to a low carbon economy. MPL recognises the need to balance commercial issues with the environmental benefits and concerns relating to energy projects and believes this balance can be responsibly delivered. The Project would be designed and developed to high quality, safety and environmental standards.





1.13. Further information on the companies referred to above is provided at: www.millbrookpower.co.uk or www.drax.com

1.14. **Policy background**

Decisions on energy Nationally Significant Infrastructure Projects (NSIPs), such as the Project, are made in accordance with Section 104 of the Planning Act 2008 which provides that in making decisions on DCO applications, the Secretary of State (SoS) must have regard to any relevant NPS and must decide applications in accordance with it unless the adverse impacts of the proposal would outweigh its benefits (or in certain other limited circumstances).

1.15. **National Policy Statements (NPS)**

NPS EN-1 - The Overarching National Policy Statement for Energy is a relevant NPS for any energy NSIP, along with the relevant technology specific NPS. For the DCO Application this includes NPS EN-2 National Policy Statement for Fossil Fuel Electricity Generating Infrastructure. The Gas Connection and Electrical Connection are below the relevant size thresholds to be categorised as NSIPs themselves. These elements are associated development, so are included in the Application. Accordingly, NPS EN-4 and EN-5 are likely to be important and relevant in the determination of the application in respect of these components.

1.16. NPS EN-1 recognises that there is a significant need for new energy infrastructure (paragraphs 3.3.7 to 3.3.9).

Millbrook | Bedford

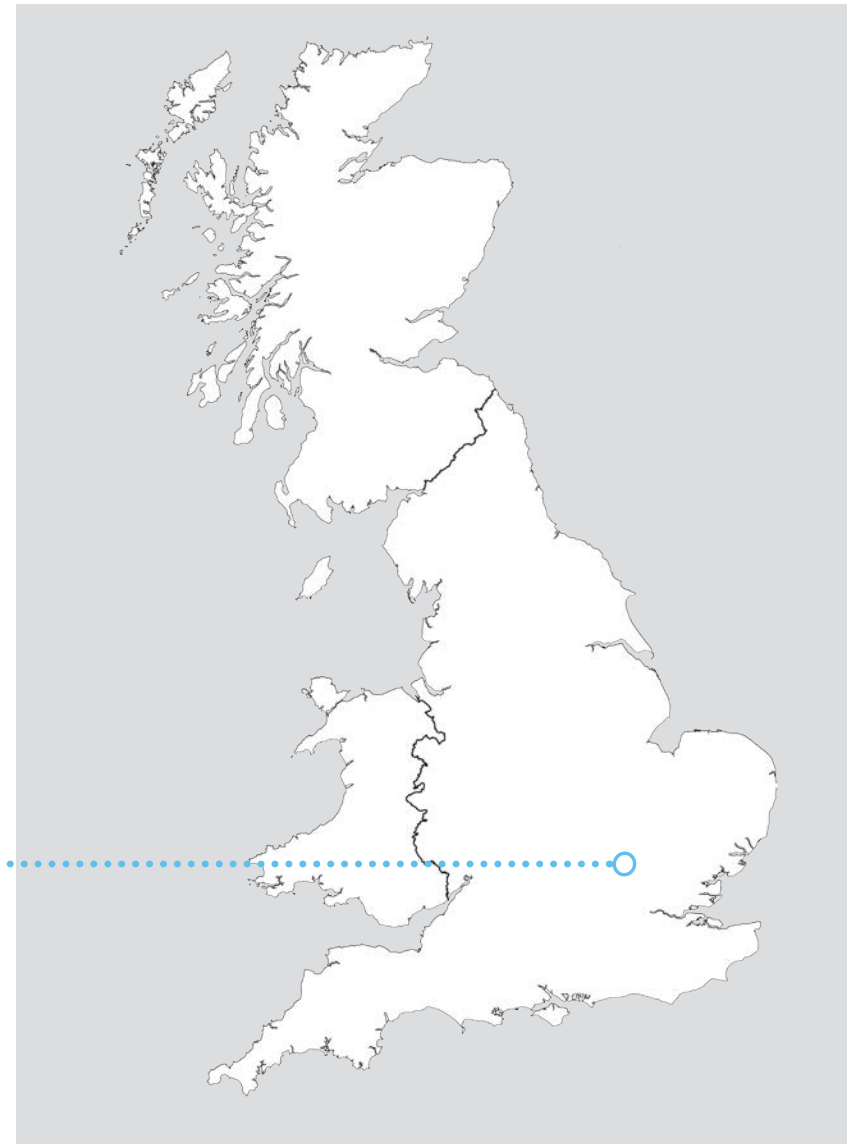

UK Location map



01. Introduction

Introduction

1.17. NPS EN-1 considers that energy NSIPs should demonstrate 'good design' and defines this in section 4.5.1 as being able to produce "sustainable infrastructure sensitive to place, efficient in the use of natural resources and energy used in their construction and operation, matched by an appearance that demonstrates good aesthetic as far as possible".

1.18. It is acknowledged that the nature of much energy infrastructure development will often limit the extent to which it can contribute to the enhancement of the quality of the area.

1.19. It is stated at paragraph 4.5.3 that the SoS shall need to be satisfied that "energy infrastructure developments are sustainable and, having regard to regulatory and other constraints, are as attractive, durable and adaptable (including taking account of natural hazards such as flooding) as they can be ... (and) that the applicant has taken into account both functionality (including fitness for purpose and sustainability) and aesthetics (including its contribution to the quality of the area in which it would be located) as far as possible".

1.20. Paragraph 4.5.3 acknowledges that "whilst the applicant may not have any or very limited choice in the physical appearance of some energy infrastructure, there may be opportunities for the

applicant to demonstrate good design in terms of siting relative to existing landscape character, landform and vegetation".

1.21. The Secretary of State seeks that applicants "demonstrate in their application documents how the design process was conducted and how the proposed design evolved" and explain the operational, safety and security requirements which the design has to satisfy.

1.22. Paragraph 4.5.5 advises that applicants consider "taking independent professional advice on the design aspects of a proposal" such as Design Review.

1.23. Specific guidance on good design for fossil fuel generating stations is provided in NPS EN-2, including that "applicants should demonstrate good design particularly in respect of landscape and visual amenity (...) and in the design of the project to mitigate impacts such as noise and vibration, transport impacts and air emissions." (Paragraph 2.3.16).

1.24. **Requirement and Purpose**
The requirement for Design and Access Statements is set out in the Department for Communities & Local Government (DCLG) guidance and information



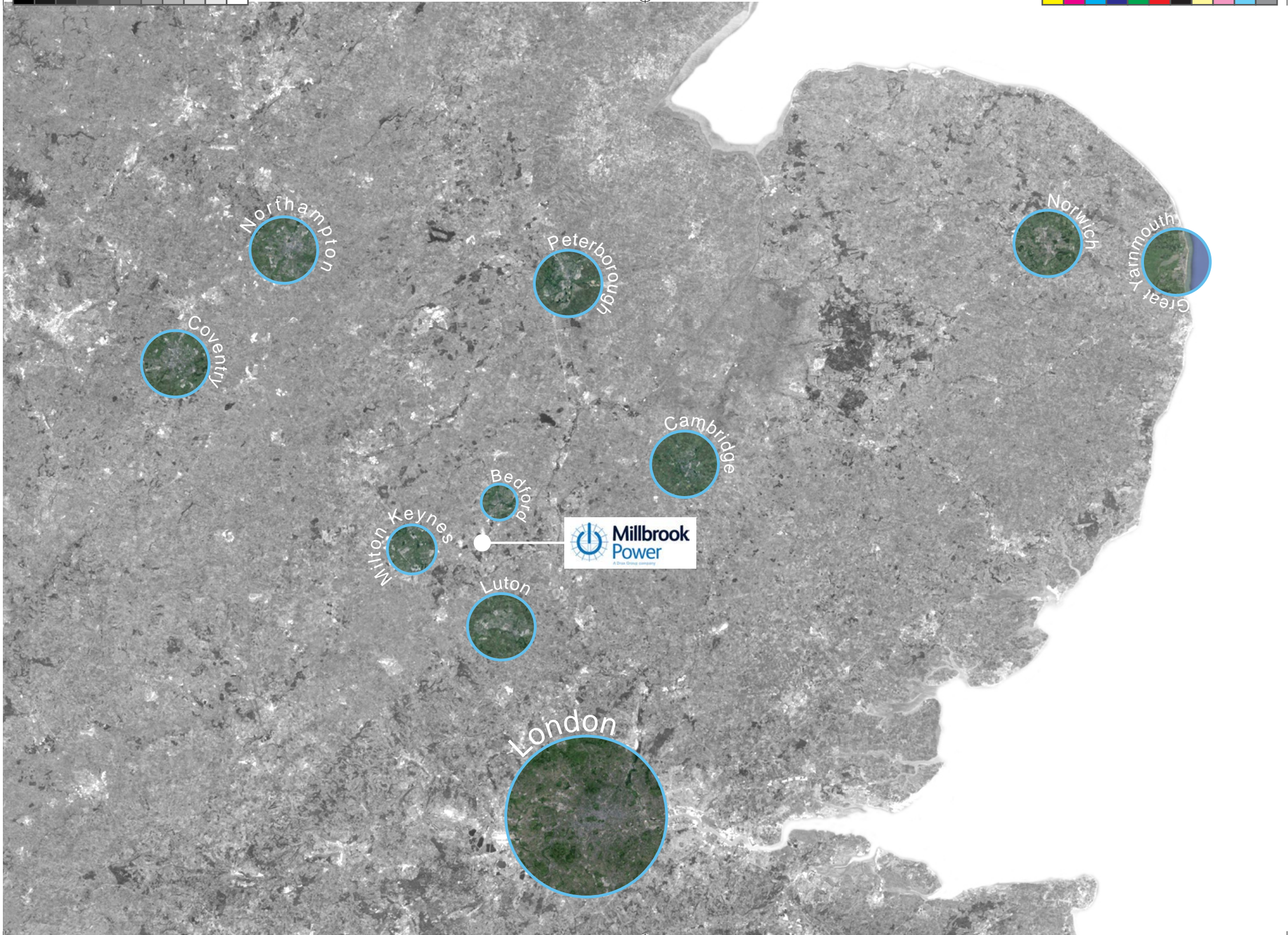

 **Millbrook Power**
A Dixi Group company

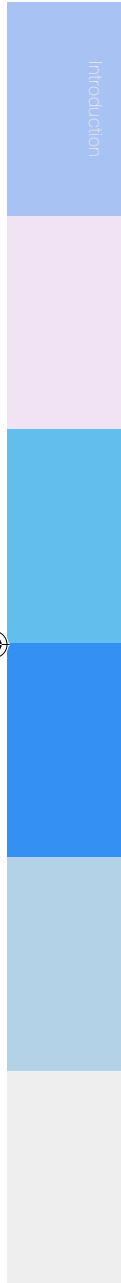

01. Introduction

requirements and validation (March 2010) – a response to the need to deliver better quality and more sustainable development through the planning system.

1.25. The guidance sets out the role of the Design and Access Statement as being to illustrate the process that has led to the Project and to explain the proposals in a structured way.

1.26. The purpose of this Design and Access Statement is, in accordance with NPS EN-1 and NPS EN-2, to assist the Secretary of State and others in:

- Understanding the site and its neighbourhood and wider context;
- Understanding the process that has led to the chosen design; and
- How the proposals have been designed to be attractive, durable, adaptable, functional, and minimise visual intrusion.

1.27. This statement should be read in conjunction with the submitted plans, Planning Statement (Document Reference 10.1), and Environmental Statement (Document Reference 6.1), which also accompany the Application. The Planning Statement describes the background to this Application in further detail.

1.28. **Consultation**

The Planning Act 2008 requires developers to consult certain prescribed bodies and the local community.

1.29. In this regard, the development of the Project has undergone extensive consultation with stakeholders, some of which has resulted in changes to the design and development of the Project.

1.30. **Document Structure**
This Statement is set out as follows:

- **Chapter 2:** Appreciating the Wider Context set out an assessment of the Project Site's wider context, connection with the wider landscape and the local areas of Millbrook and other surrounding villages. This will be described in terms of Built Form and Visual Structure; Movement and Connections; and Landscape and Ecology.
- **Chapter 3:** Site Setting sets out a more detailed focus of the site and immediate surroundings of Rookery South Pit, described in terms of Built Form and Visual Structure; Movement and Connections; and Landscape and Ecology.
- **Chapter 4:** Design Response sets out key design principles which inform the proposals for the site.

- **Chapter 5:** Indicative Development Proposals presents 2D and 3D illustrations of the proposed scheme with a detailed description of use and amount, layout and access, scale and massing, landscape and appearance.
- **Chapter 6:** sets out the Summary & Conclusions of the Statement.

1.31. The key factors for consideration when selecting a suitable site for the Project were broadly fourfold: technical, environmental, economic and whether the location of the development site would be in line with local planning policy.

1.32. **Technical & Economic Considerations**
The site selection process began in 2010. A range of sites around the UK were looked at in order to find suitable locations to support power generation





LOCATION PLAN

KEY

-  Project Site Boundary
-  M1 Motorway
-  Railway Lines



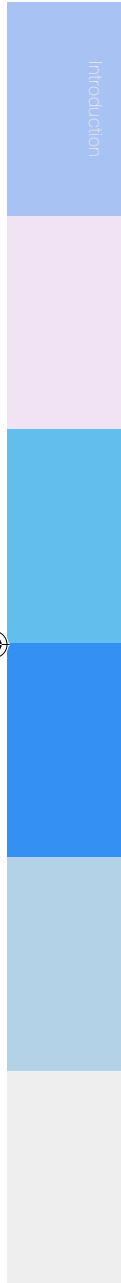

01. Introduction : Why Millbrook

plants of this nature. The search focused on areas that would meet the following key strategic criteria:

- Acceptable proximity to the National Transmission System and NETS or local distribution networks;
- Located within areas that are net importers of electricity;
- Located within areas of compatible land use designation/s;
- Size of site suitable to support a power generation plant of up to 299 MW, as well as infrastructure such as gas and electrical connection

1.33. Environmental Considerations

From an environmental perspective, during the site selection process MPL has to consider the location of the site in relation to sensitive receptors such as residential properties or sites of ecological importance (to avoid unacceptable impacts such as those from noise and visual disturbance, or air quality impacts), the current nature of the surrounding area (to limit impacts on the landscape character of the area), previous site uses and land quality (to avoid sterilisation of the best and most versatile agricultural land or mineral assets) and proximity to sensitive ecological habitats.

1.34. Other Sites

Drax is bringing forward three other similar power generation projects. They are: Progress Power Ltd at Eye Airfield in Suffolk, which received Development Consent in July 2015 (www.progresspower.co.uk); Hirwaun Power Ltd at Hirwaun in South Wales, which received Development Consent in July 2015 (www.hirwaunpower.co.uk); and Abergelli Power Ltd at Abergelli in South Wales, which is in the pre application phase of the Planning Act 2008 process (www.abergellipower.co.uk).

1.35. Project Site

Based on these site considerations, a number of reasons meant that Rookery South Pit was selected as a suitable location for the Project.

- Close proximity to gas National Transmission System – both National Transmission System feeder 7 and National Transmission System feeder 9.
- Close proximity to a suitable electrical connection – the existing Grendon to Sundon 400kV overhead line.
- In a location with adequate space to develop the Power Generation Plant, and gas and electrical connection infrastructure.
- Located within previously developed land.
- Lies below ground level which is useful in

screening the Project.

- Located within an area identified as being potentially suitable for energy infrastructure.
- Situated in an area with a well-developed road network.
- Located outside of areas at risk of flooding.
- Located in an area which is a net importer of electricity signifying existing demand for this type of development.

1.36. More discussion about site selection can be found in the Environmental Statement (Document Reference 6.1), chapter 5 'Alternatives Considered', as well as Planning Statement (Document Reference 10.1).





Location Overview I

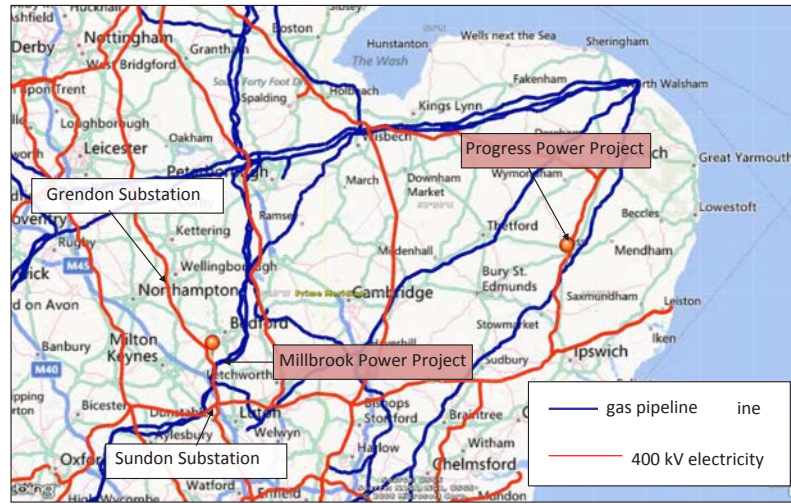

Site Detail I

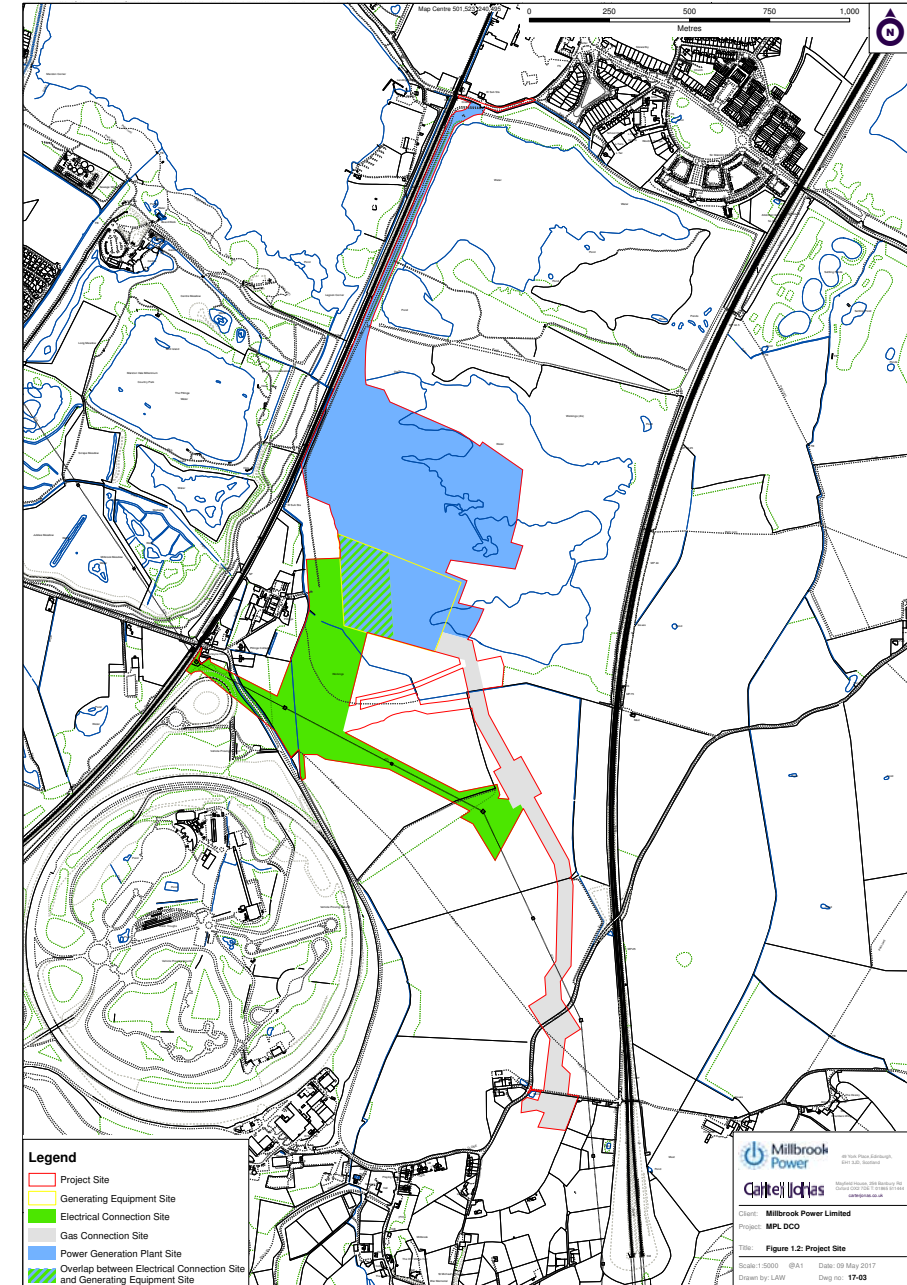
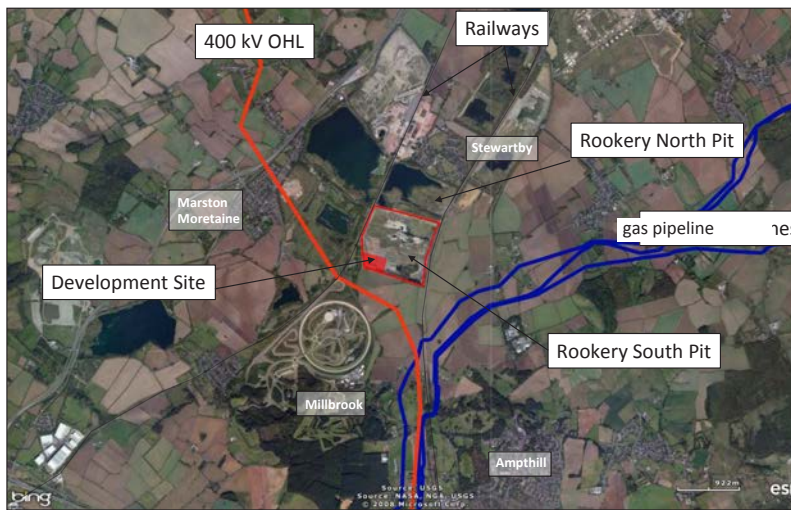



02. Appreciation of Wider Context

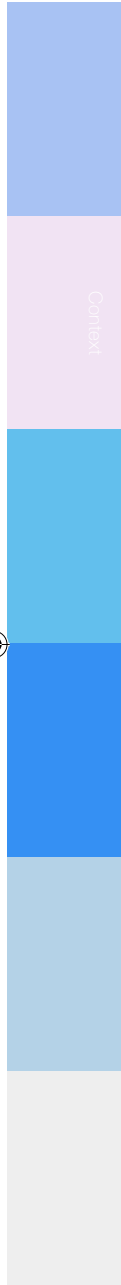

2.1 Appreciation of Wider Context

2.1.1. This chapter describes the Project Site at two spatial scales of context. Initially from a historic context and then, an overview of the Project Site's wider, strategic context along with consideration of the site's immediate context described under the headings of:

- **Built form and visual structure;**
- **Movement and connections; and**
- **Landscape.**

2.1.2. A number of emerging principles will be identified at this spatial scale and will be taken forward to influence the key design principles for the Project Site described in chapter 4.

2.1.3. Strategic setting

The Power Generation Plant Site and part of the Gas and Electrical Connections would be situated on land within former clay pits known as 'The Rookery', covering an area of some 210ha, and situated in the Marston Vale between Milton Keynes and Bedford, approximately 3km north-west of Ampthill, and 7km south west of Bedford.

2.1.4. The Rookery is situated within a post-industrial landscape, which is presently undergoing significant change. It comprises two large former clay pits, Rookery North and Rookery South Pits, separated by an east-west spine of unexcavated clay. The Generating Equipment Site, Laydown Area and parts of the Access Road and Gas and Electrical

Connections would be located within Rookery South Pit which is approximately 95ha and is bound by steep clay banks that are varied in nature and substrate. Part of the Access Road would lie within Rookery North Pit.

2.1.5. Road access to the Power Generation Plant Site is currently from the north near Stewartby via the A421, Bedford Road and Green Lane. There is a junction on Green Lane leading to an access track which extends southwards into Rookery South Pit and the Generating Equipment Site. The Gas and Electrical Connections would be primarily accessed from the A421, northwards along the A5141, westwards then southwards for approximately 7km along the B530 (referred to variously along its route as Ampthill Road / Hardwick Road / Bedford Road / Hazlewood Lane) to Millbrook Road, Houghton Lane then (in the case of the Electrical Connection) Station Lane.

2.1.6. The Gas and Electrical Connection would be located largely outside of Rookery South Pit, within a mostly undeveloped agricultural landscape which includes areas of woodland, native hedgerows and a number of water-bodies such as ditches.

2.1.7. Nearby roads include the A421 which is approximately 2km to the west and the B530 which lies to the east of the Project Site. The A421 connects directly to Junction 13 of the M1 Motorway which is approximately 5.6km to the south west of the Project Site. Furthermore the Midland Mainline Railway and

Marston Vale Line border the Power Generation Plant Site to the east and west respectively.

2.1.8. The closest residential dwelling to the Power Generation Plant Site is South Pillinge Farm, located approximately 130m to the west of the Project Site boundary. South Pillinge Farm is separated from the Project Site by a small deciduous woodland. To the north of Green Lane and The Rookery lies Stewartby. Other neighbouring residential areas include: Houghton Conquest approximately 1.5km to the east of the Project Site boundary; Marston Moretaine approximately 1.2km to the west; and Millbrook approximately 400m to the south.



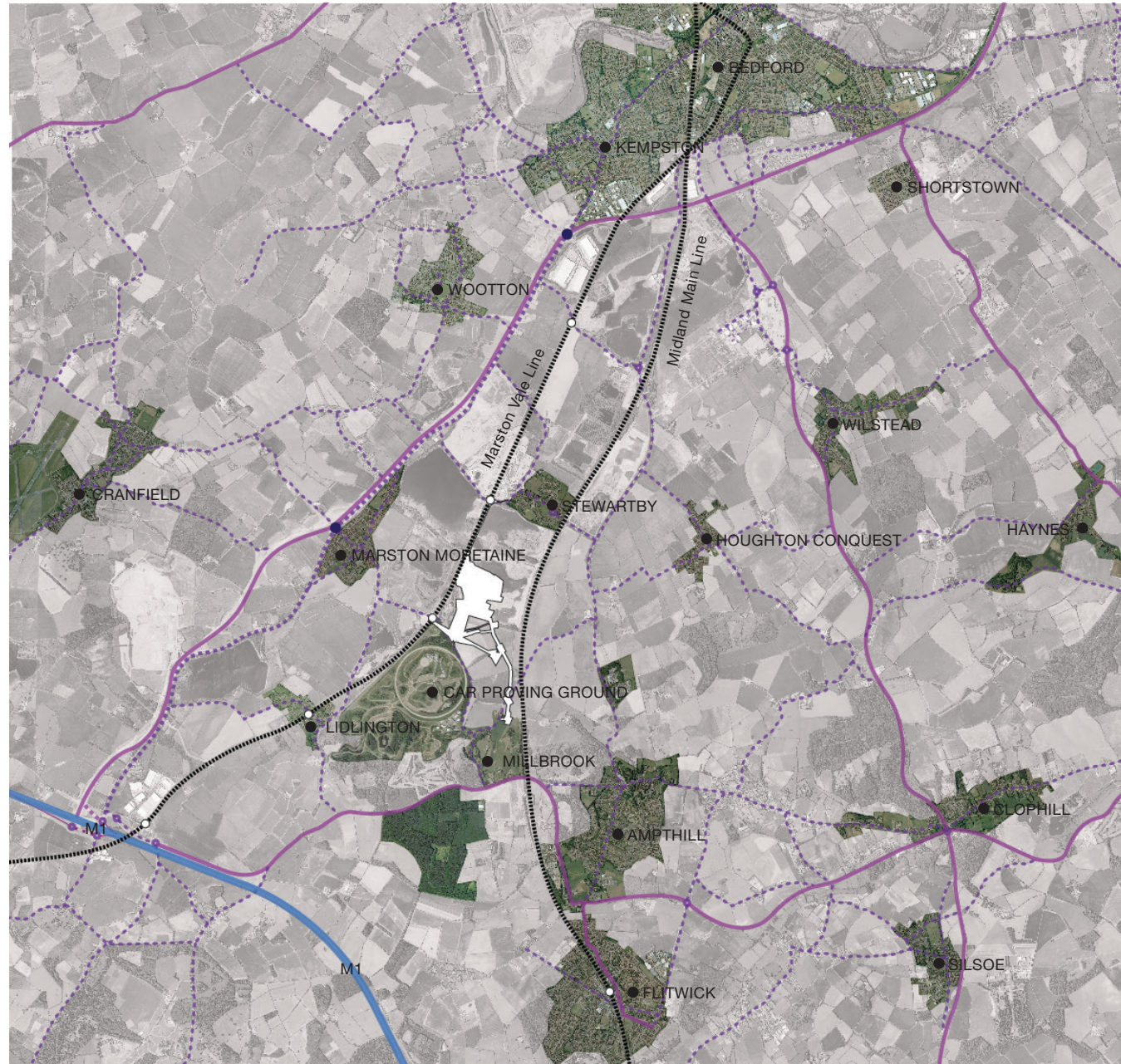

2.1.9. To the west of the Project Site is Marston Vale Millennium Country Park, which provides habitat conservation opportunities, indoor and outdoor community amenities and a wind turbine. There is also a Forest Centre within the Marston Vale Millennium Country Park located just to the south of Stewartby Lake which provides the focal point for the indoor and outdoor community amenities. Millbrook Proving Ground, a vehicle testing ground, is located to the south west of the Electrical Connection.





ROAD NETWORK

KEY

-  Project Site Boundary
-  M1 Motorway
-  Main Road
-  Secondary Road
-  Railway Lines





2.2 Appreciation of Wider Context

2.2.1. Landscape Character

The Project is located within the North Marston Clay Vale, a large-scale landscape with a low-lying, flat landform providing distant views in all directions.

2.2.2. To the south of the Clay Vale lies an elevated wooded, mixed greensand/sandstone escarpment the Greensand Ridge, to the west is the Milton Keynes Clayland Fringe used predominately as farmland. These elevated landscapes form prominent backdrops and offer a sense of containment.

2.2.3. The North Marston Clay Vale landscape is characterised by large geometric field units with variable field boundaries including remnant hedgerows, scrubby margins and drainage channels. Mature woodland is relatively scarce, the area does contain Marston Thrift SSSI, a nationally important ancient ash / maple woodland site and other areas of ancient woodland with Wootton Wood, forming the heart of The Forest of Marston Vale. The North Marston Clay Vale has several dominant land uses:

- Arable farming contained within large open fields,
- Large scale clay extraction for the brick making industry,
- Areas of landscape restoration notably the flooded clay pits forming a series of lakes,
- The ongoing establishment of the Forest of Marston Vale,
- Areas of landfill.

2.2.4. Historically the Clay Vale's extensive extraction supported the areas brick work industry leading to extensive disturbance of the landscape and providing a strong industrial character. The Vale is currently in the process of large scale restoration of previous extraction sites to create new landscape features in the environment.

2.2.5. The agricultural landscape is further fragmented by current and former industrial activity including open cast clay pits, landfill, distribution centres and industrial estates. The most visibly prominent industrial features are the line of Stewartby Brick work chimney stacks to the North of the Project Site and further out, the airship sheds at Shortstown and large distribution warehouses south of Bedford. Lines of pylons cut across the landscape and are highly visible extending from the Greensand Ridge.

2.2.6. The Forest of Marston Vale stretching between Bedford, Ampthill and Milton Keynes is one of 12 Community Forests in England. Flooded clay pits form a series of lakes throughout the vale providing valuable ecological, recreational and landscape resources such as at Stewartby Country Park.

2.2.7. A number of busy transport routes cut north south through the landscape including the M1, A421(T) the A6 and two railway lines, the Marston Vale Line and Midland Mainline. Both have an audible and visual presence in the landscape.

2.2.8. Bedford, on the northern boundary, brings strong urban fringe characteristics to the landscape - large scale industrial estates/retail parks south of Kempston typifying views to the town. Settlement occurs across the Vale, often associated with minor tributary valley, characterised by a mix of building age, style and materials. Significant late 20th century development has resulted in the coalescence of settlement as at Wootton and Marston Moretaine.

2.2.9. By contrast to the North Marston Clay Vale, the elevated landscape of the Greensand Ridge, to the south, has a more intact and static character. The key defining features include a strong wooded context with extensive areas of deciduous woodland, mixed woodland and coniferous plantations; a strong underlying heathland character; a large number of historic parks and gardens, with parkland forming a dominant land use influencing the wider landscape; and far-reaching, clear views across the low clay Vale.

2.2.10. The western and northern limits of the ridge are dominated by intensive farmed arable land, though important features such as blocks of ancient woodland, valleys and streams are also found. This landscape is in a state of transition, exemplified by significant development at Cranfield together with the development of roads, pylon lines and the frequent occurrence of other 'fringe' land uses.

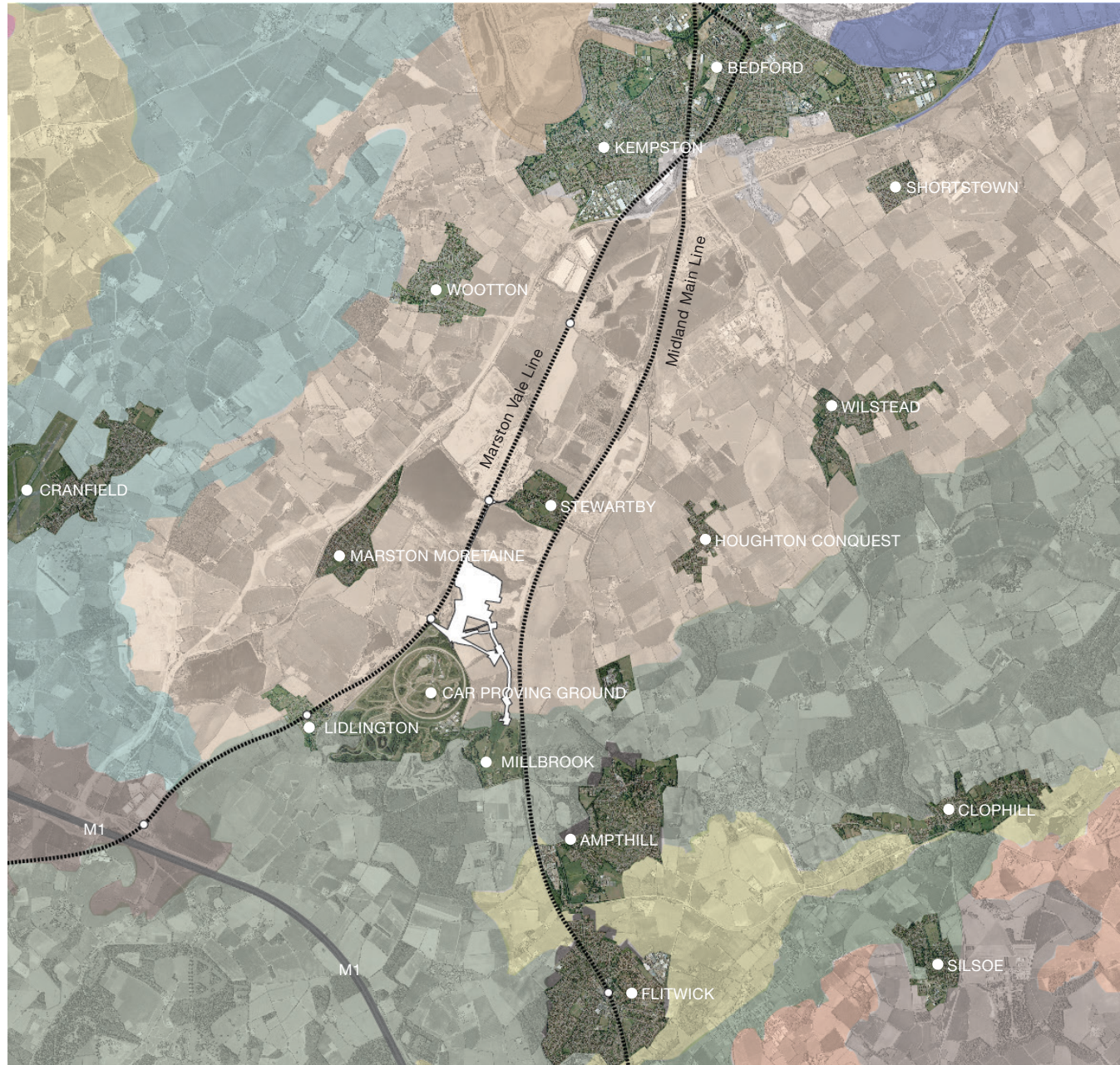

LAND TYPES

KEY

-  Project Site Boundary
-  Urban
-  Chichley / Crawley Claylands
-  Clay Farmland
-  Wooded Wolds
-  Limestone Valleys
-  Clay Valleys
-  Clay Vale
-  Wooded Greens & Ridge
-  Greensand Valley
-  Clay Hills





2.3 History of Wider Context

2.3.1. The rapid expansion of the brick industry in the 20th century affected the settlement pattern of the Vale, but it is still possible to identify older (medieval) villages at Wootton, Marston Moretaine, Houghton Conquest and Lidington.

2.3.2. All of the villages have been greatly enlarged by 20th century house building, but there is a small historic core to each settlement. Only Church End, Wootton and Stewartby are designated as Conservation Areas within the immediate vicinity of the Project Site. The villages are associated with medieval churches, many of which are Grade I or II* Listed which tend to be located on the edge of the village with towers that form local landmarks in the Vale. A number of smaller hamlets and isolated farmsteads certain remnants of medieval moated sites, some designated as Scheduled Monuments. Others have Grade II and II* Listed farmhouses.

2.3.3. Key cultural heritage assets of relevance to the design of the Project comprise:

A. Ampthill Park - lies to the south east of the MPL project site and is a Grade II Registered landscape located on the north side of Ampthill and extends from the crest of the ridge down into the Vale. The park encompasses Ampthill Castle, (a Scheduled Monument, which is now marked by an 18th century memorial cross to Katherine of Aragon (Grade II Listed). The Park is now a public park;

B. Ampthill Park House - lies to the south east of the Project Site and is a Grade II* Listed building located towards the foot of the scarp with views over the vale to the north-west. The house is now detached from the surviving portions of its 18th century designed landscape of the Park and is a private house in multiple ownership. The house overlooks the Project Site at a lower elevation than Ampthill Park;

C. Millbrook Village - lies to the west of Ampthill Park and is a Conservation Area. The village has good examples of estate houses built for the Duke of Bedford which are strung along the main village road. The medieval church (Grade II* Listed) is sited in a prominent high point above the village and is a landmark on the scarp when viewed from the Vale below. The northern end of the main village road joins Station Road and looks towards the Project Site across intervening undulating farmland;

D. Houghton House - lies to the east of the Project Site and is a Grade I Listed building and a Scheduled Monument and was built in the early 17th century as a hunting lodge and survived until 1794 when it was partially dismantled. The house is located in a commanding position just below the crest of the ridge with north-facing views over the Vale. The house is a publicly accessible monument and overlooks the Project Site;



Ampthill Park House



Houghton House



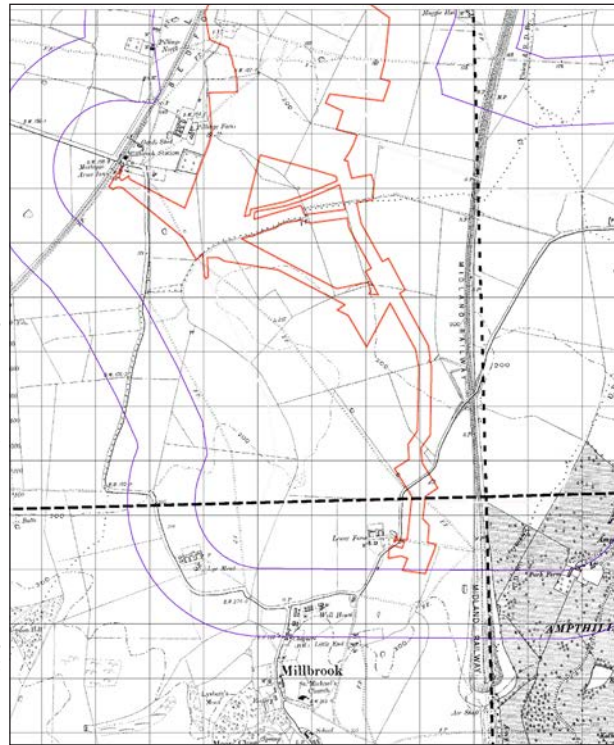

© Crown Copyright and Landmark Information Group Limited 2014, all rights reserved.

Historical Site Map 1901

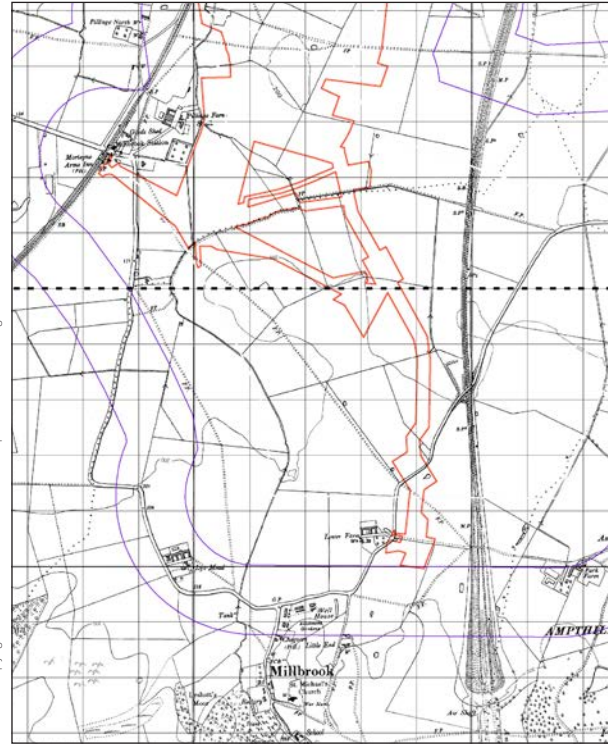

© Crown Copyright and Landmark Information Group Limited 2014, all rights reserved.

Historical Site Map 1960

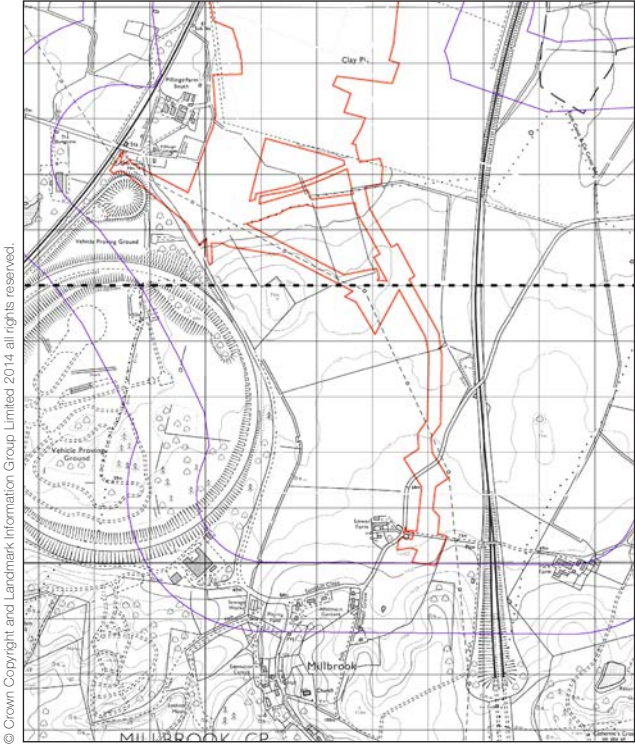

© Crown Copyright and Landmark Information Group Limited 2014, all rights reserved.

Historical Site Map 1990



Stewartby Brick Works



Stewartby Brick Works



Stewartby Brick Works



Millbrook Station 1959





2.3 History of Wider Context

E. Stewartby - lies to the north of the Project Site and within the Vale and is in part designated as a Conservation Area. The village is generally inward facing with a tree screen separating it from the Project Site;

F. Cardington Hangars - which are former air ship hangars, lie to the north east of the Project Site and some 8km distant. The buildings are Grade II* listed and lie within an flat open former airfield outside Bedford.

2.3.4. Of particular local importance is Stewartby Brick Works and the four remaining chimneys to the west of the village. The chimneys and two Hoffman Kilns of the former brickworks are Grade II Listed.

2.3.5. Other listed buildings in close proximity to the Project Site include South Pilling Farm (Grade II Listed).

2.3.6. The decommissioned conveyor over the Marston Vale Line has been partially demolished.

2.3.7. The proximity of the cultural heritage assets identified has been a major influence driving the design of the Project giving consideration to siting of buildings, landscape integration strategy and building design. In many instances the design of the Project has been tested during the iterative process in assessment view points from these cultural assets.

2.3.8. The excavation of the pit has led to the destruction of assets where clay extraction occurred.

2.3.9. Within the Rookery, evidence of past land uses remain in the form of brick piles and other detritus, and include parts of the decommissioned conveyor which previously crossed the Marston Vale Line to the north west of Rookery North Pit.

2.3.10. These cultural heritage assets referred to above did not significantly affect the development of the Project.

2.3.11. All designated and undesignated cultural heritage assets within a 3km radius of the Project Site together with selective sites of greatest cultural heritage merit within a 10km radius of the site are illustrated opposite.

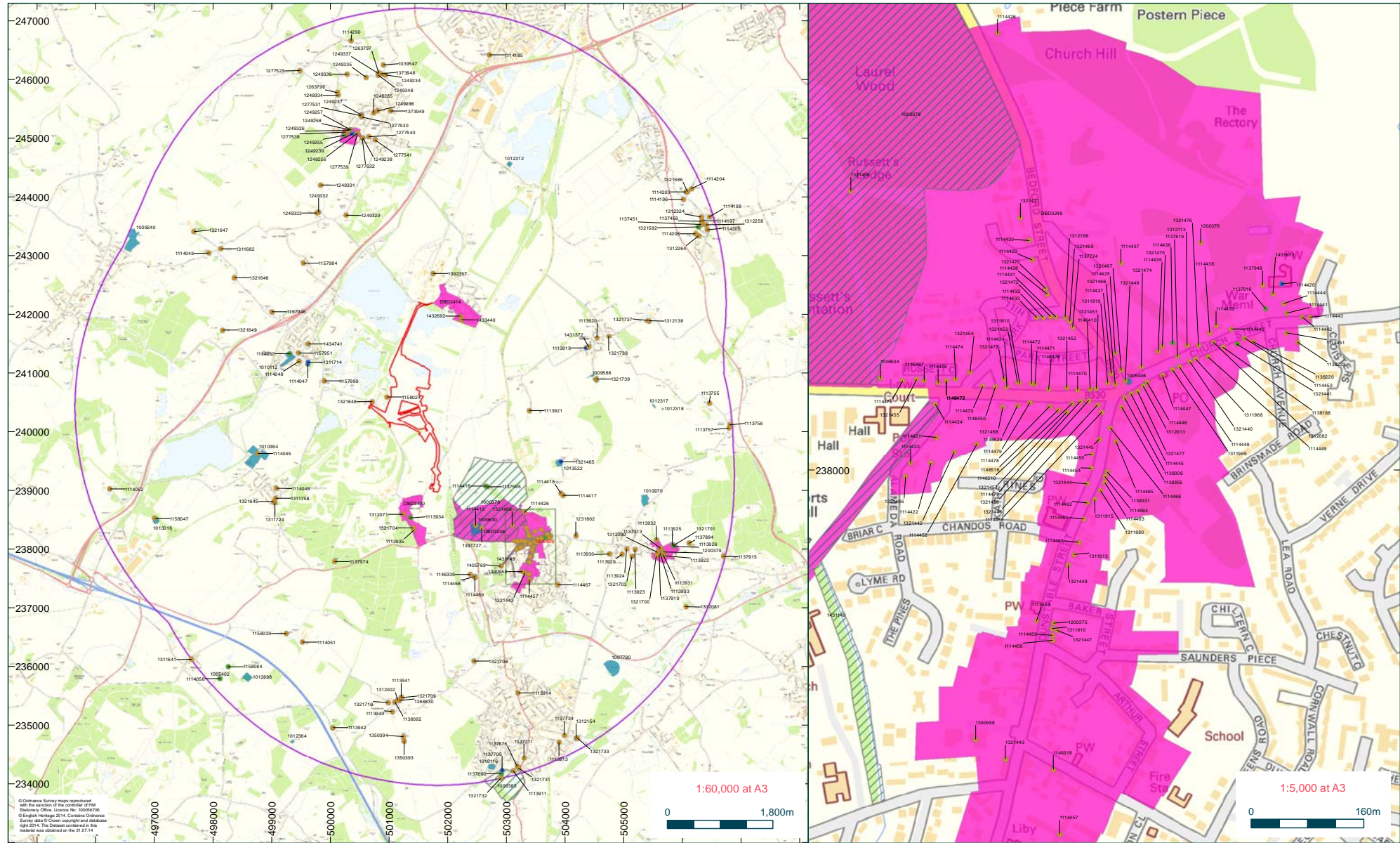

© Ordnance Survey map reproduced with the permission of the controller of Her Majesty's Stationery Office. Licence No: 100054706
 © English Heritage 2014. Creative Commons Attribution 4.0 International License
 Survey data © Crown copyright and database right 2014. The dataset contained in this material was obtained on the 31.07.14

- Legend**
- Project site
 - Grade I Listed Buildings
 - Scheduled Monuments
 - 5km buffer
 - Grade II* Listed Buildings
 - Registered Parks and Gardens
 - Location of inset
 - Grade II Listed Buildings
 - Conservation Area





2.4 Strategic Setting



- 01 View looking north from southern extent of Rookery South Pit showing Stewartby Brick Work Towers
- 02 View from Amphill Park looking northwest across the Vale
- 03 View of Former Stewartby Brick Works
- 04 Former Stewartby Brick Works
- 05 Former Stewartby Brick Works
- 06 Former Stewartby Brick Works
- 07 Marston Vale Railway line

01	
02	03
04	05
06	07



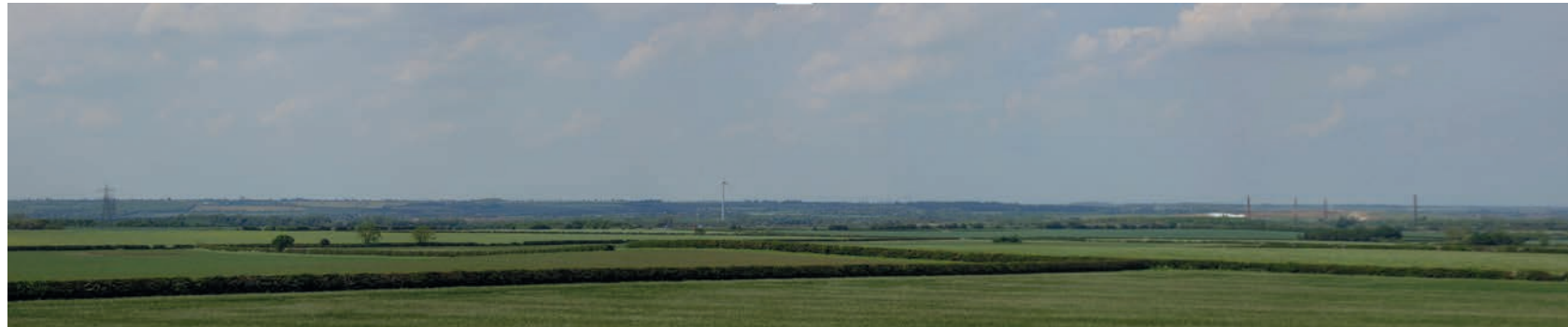

- 01 Panorama looking North from Project Site
- 02 Millbrook Huntings Beyond © William Stephen.
- 03 View from Millbrook showing existing wind turbine and electrical pylons.
- 04 View looking South from Rookery North Pit open water.

01	
02	03
04	





2.5 Wider Context - Built Form & Visual Structure

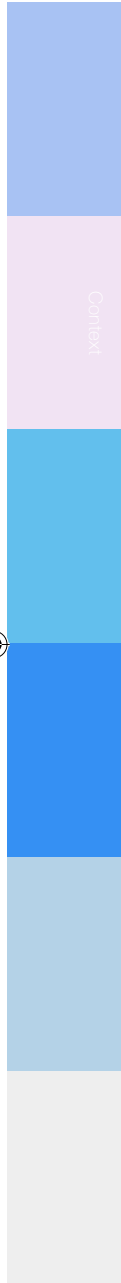

Context

- 2.5.1. The Project lies in the Forest of Marston Vale, an evolving community forest which runs south west from the towns of Bedford and Kempston in towards the M1 motorway. The Vale is traditionally a brickmaking area, and consequently there are a number of large empty pits, some of which have now been converted into lakes.
- 2.5.2. The wider context to the Project Site is predominantly rural, interspersed with farm, villages and market towns. The closest villages to the Project Site are Millbrook, Stewartby, and Lidlington, with Ampthill, Houghton Conquest and Wootton lying further out.
- 2.5.3. The nearest major settlements are Bedford 9km to the north and Milton Keynes 16km to the west.
- 2.5.4. To the North of the Project Site is the village of Stewartby, which is part of a designated Conservation Area. The village grew rapidly to house workers of the Stewartby Brick Works and operated under various ownership from 1897 to 2008. The four remaining brick towers are a highly visible local landmark and have been used as a reference point for the Project design and mitigation.
- 2.5.5. Another highly visible landmark is the Marston Mill Wind Turbine (120.5m to tip) at the Marston Vale Forest Centre to the immediate west of the Project Site. With blades approximately 35m long the Marston Mill is estimated to produce around 4,500,000KWh of electricity per year.
- 2.5.6. The Marston Vale Forest Centre is located on reclaimed clay pits similar to Rookery South Pit. The clay pits are characterised by large bodies of open water and woodland planting.
- 2.5.7. The skyline in the area of the Project Site, with its disused brickworks chimneys and the Marston Vale Forest Centre Wind Turbine is further cluttered by the electricity pylons of the Grendon – Sundon 400kV overhead line, which run more or less in a north-south direction.
- 2.5.8. The largest body of water in the proximity of the Project Site is the 200 acre Stewartby Lake situated northwest. The Lake is home to the Stewartby Water Sports Club offering a range of activities such as Angling, Sailing, Skiing, and Power Boat Racing.



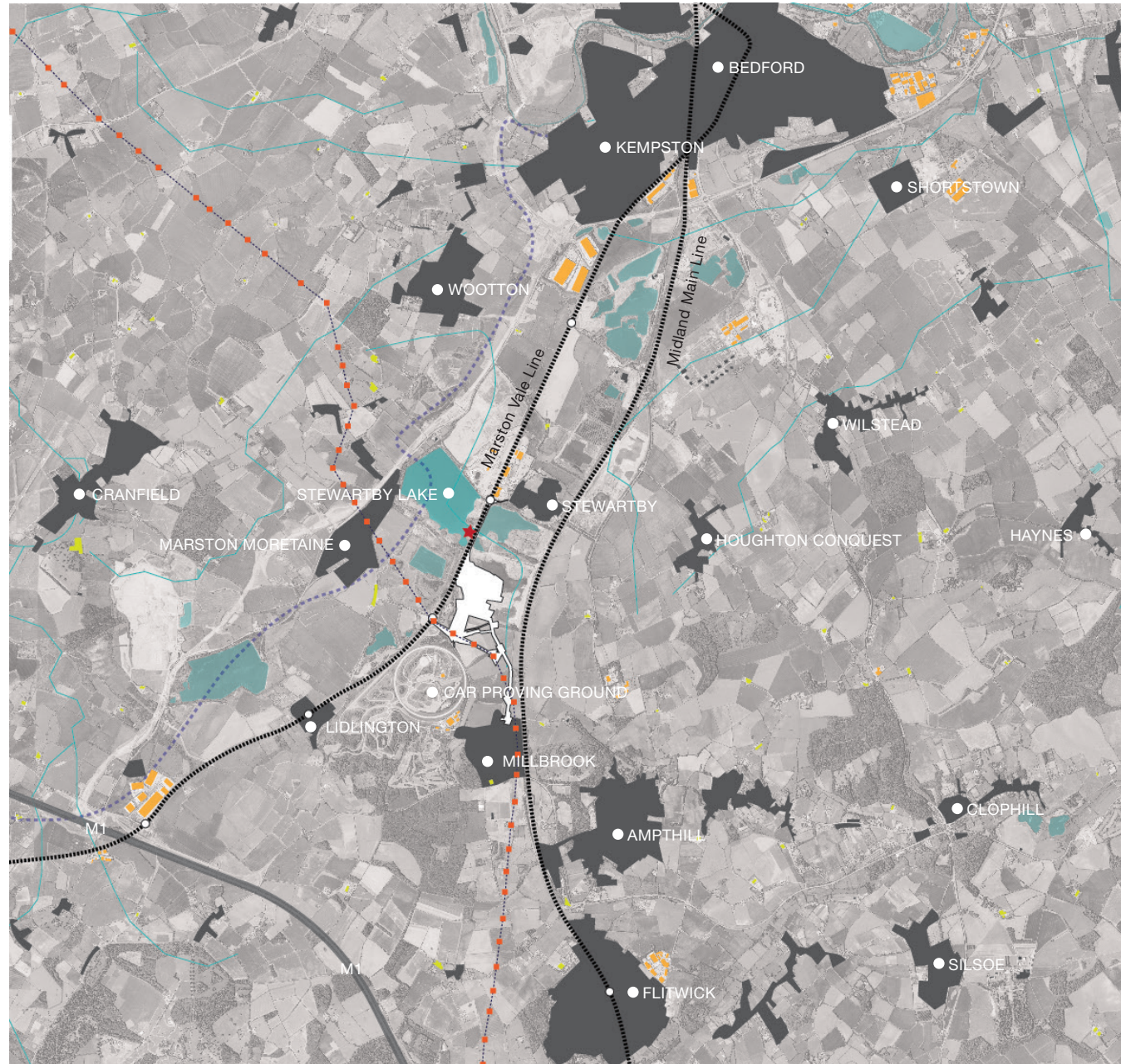

BUILT FORM DIAGRAM

KEY

-  Project Site Boundary
-  Watercourse
-  Proposed Bedford & Milton Keynes Waterway
-  Towns & Villages
-  Farm Buildings
-  Industrial Buildings
-  Power Line + Pylon
-  Marston Mill Wind Turbine





2.6 Wider Context - Built Form & Visual Structure

Context



- 01 St Michael & All Angels Church, Millbrook
- 02 The Forest Centre, Forest of Marston Vale
- 03 Former Brick Works, Stewartby from Marston Vale Rail Line
- 04 Thatched cottages in Woburn Street, Ampthill. Built 1812-16
- 05 Former Brick Work Towers from Stewartby Water Sports Club
- 06 Remaining Tower of Stewartby Brick Works



01	02
	03
04	05
	06





- 01 Lidlington Panorama
- 02 Lockheed Martin, Amptill
- 03 Amptill Market Place
- 04 The Bell, Marston Moretaine
- 05 Amptill Antiques Emporium
- 06 Disused Warehouse Stewartby
- 07 The junction between Station Lane and Sandhill Close, Millbrook. Looking southeast.

01	02	
03	04	05
06	07	





2.7 Site Setting : Visual Context

2.7.1. There is significant intervisibility between the distant elevated Greensand Ridge landscape and the flat, low lying, clay vale in which the Project is to be located.

2.7.2. The nearest residential dwellings and settlements to the Power Generation Plant Site are South Pillinge Farm to the south west (an isolated farm and associated cottages), Stewartby to the north and Marston Moretaine to the west. From these locations views of the Power Generation Plant Site are substantially screened in many ways by built development, woodland areas, tree belts and hedges. Where views over the Project are anticipated, these have influenced the layout of the Generating Equipment Site to minimise the proportion of new buildings that are visible from these viewpoints.

2.7.3. The Marston Vale Millennium Country Park is located immediately to the west of the Power Generation Plant Site. Views towards the Project from the rear elevation of the Forest Centre are screened by intervening woodland within the Country Park. The extent of view from the Country Park is likely to change over time as young woodland planting matures. From footpath FP72 within the Park, there are open views towards where the Project will be located, although views into the base of Rookery South Pit are screened by low level scrub planting along either side of the Marston Vale Line.

2.7.4. The views from the Country Park are an important consideration addressing amenity considerations and cultural associations. The Forest Centre promotes sustainable environmental initiatives and recreation and the Project promotes sustainable energy production.

2.7.5. The views marked on the plan below show the key viewpoints used in the LVIA Project Landscape and Visual Impact Assessment. They are:

- VP 01 View From Footpath South West of Stewartby.
- VP 02 View From Footpath by Chequers Pub.
- VP 03 View From Ampthill Park, Katherine's Cross.
- VP 04 View From Houghton House.
- VP 06 View From Green Sand Way / B530.
- VP 06a View From Country Park Access.
- VP 06b View From Country Park Visitor Centre.
- VP 08 View From Marston Church Path.
- VP 09 View From Footpath Junction North of Lidlington.
- VP 10 View From the Kennels, Cranfield.
- VP 11 View From Picnic Area Lidlington.
- VP 12 View From Green Lane.
- VP 13 View From Hill Farm Bridleway.
- VP 14 View From Footpath Option Land.
- VP 15 View From Station Footpath Option Land.

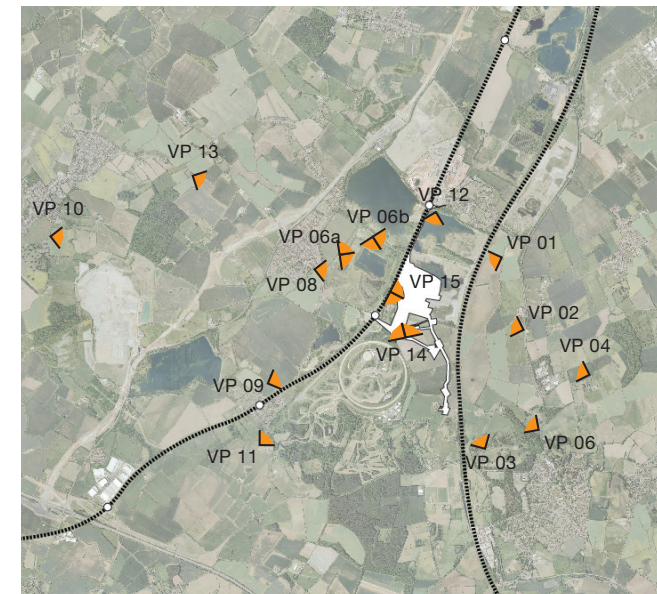

MPL Photomontage Location Map





VP 03 View From Amphill Park, Katherine's Cross showing existing Marston Vale Wind Turbine and Stewartby beyond



VP 14 View from footpath to the south of the Project Site showing existing Marston Vale Wind Turbine



VP 14 View from footpath to the south of the Project Site showing existing Marston Vale Wind Turbine





2.8 Wider Context: Movement & Connections

2.8.1. Roads

The A421 joins the M1 at Junction 13 and forms the principal local transport corridor close to the Project Site, extending northeast-southwest and linking to the A1.

2.8.2. The M1 runs in a Northwest-Southeast direction 5km to the South / West of the Project Site and forms one of the main strategic north-south highway routes through Great Britain. It connects some of the major conurbations of the north (Sheffield, Leeds), the Midlands (Nottingham, Northampton), Milton Keynes and London. A connection from the M1 to the M6 provides a link to Liverpool, Manchester and Birmingham.

2.8.3. The existing A421 has recently been subject to major improvement works, creating a new A421 dual and 3-lane carriageway between Bedford (at the southern by-pass) and the M1. Works include re-routing of the carriageway to the west of Marston Moretaine, new junctions provided at Marston Moretaine and at Marsh Leys and major improvements to Junction 13 on the M1.

2.8.4. The A507 by passes Ampthill to the south east; and the A6 extends north-south into Bedford. The A421 connects Bedford and Milton Keynes.

2.8.5. The Project Site will be accessed from the former A421, now known as C94, via Green Lane, which is an unclassified road providing access to the former

Stewartby brickworks site and Stewartby, connecting with the B530. The road crosses the Marston Vale Line at a level crossing and passes under the Midland Mainline to the east of the village via a low bridge with height restriction where Stewartby Way meets the B530.

2.8.6. Railway

Both the Stewartby and Millbrook Rail Stations are served by the Marston Vale Line that provides an hourly service operated by London Midlands in each direction between Bedford and Bletchley from Mondays to Saturdays (16 trains per day in each direction).

2.8.7. There are links from Millbrook and Stewartby Rail Stations to Bedford, Bedford St Johns, Kempston Hardwick, Lidlington, Ridgmont, Aspley Guise, Woburn Sands, Bow Brickhill, Fenny Stratford and Bletchley.

2.8.8. The Midland Main Line runs to the east of the Project Site providing services from Bedford to London St Pancras, the Midlands and northern England. The nearest railway station to the Project Site served by the Midland Main Line is the Bedford Railway Station, served by the adjacent Marston Vale Line, located approximately 9.3km north-east from the centre of the Project Site.





ROAD NETWORK

KEY

-  Project Site Boundary
-  M1 Motorway
-  A Class Roads
-  B & C Class Roads
-  Railway Line





2.8 Wider Context: Movement & Connections

2.8.9. Public Right of Way

There are over 1341km of public rights of way in Central Bedfordshire that run between towns and villages and out into the wider countryside. Central Bedfordshire Council are responsible for the day to day maintenance of the network which consists of 975 km of Public Footpaths, 340km of Public Bridleway and 26km of Byways Open to All Traffic (BOATS). These rights of way are recorded on the Definitive Map and Statement that can be found at: <http://www.centralbedfordshire.gov.uk/onlinemapping/map.aspx>

2.8.10. Footways

The most prominent footway to the Project Site is the John Bunyan Long Distance Walkers Association Trail. The trail stretches from Pavenham in the north to Lilley in the south with the trail running through the Village of Millbrook and Ampthill Park.

2.8.11. The Milton Keynes Boundary walk, 8km to the north west of the Project Site, is a 60km route around the Milton Keynes town boundary through the valleys of the Rivers Tove and Ouse. The landscape includes canal towpath, forest and thatched cottages using mainly existing footpaths.

2.8.12. The Greensand Ridge Walk passes through Bedford, Buckinghamshire and Cambridgeshire. The route follows a ridge of greensand which rises from the clay vales on either side.

2.8.13. The 64km walk starts in Leighton Buzzard and finishes in Gamlingay, Cambridgeshire. The route has been split into five sections to enable the route to be walked in stages or as a whole. The Stages are:

- Leighton Buzzard to Woburn 13km
- Woburn to Ampthill 15.5km
- Ampthill to Haynes 13.5km
- Haynes to Sandy 11.5km
- Sandy to Gamlingay 8.5km

2.8.14. Cycle Routes

National Cycle Route (NCR) 51 connects Milton Keynes to Bedford. The route follows the north bank of the River Great Ouse through Bedford town, before crossing the river into Kempston and the Bedford western bypass via Wootton to Marston Moretaine.

2.8.15. The route travels through the Forest of Marston Vale where there is a cycleway connecting with Millbrook railway station.

2.8.16. From the Forest of Marston Vale, the NCR 51 takes residential roads, tracks, and bridleways to Cranfield.

2.8.17. At Cranfield, there are no further NCR signs westbound until Salford, where the route crosses the M1 towards Wavendon and Woburn Sands before entering the eastern edge of Milton Keynes.









2.8.18. Bedfordshire Cycle Route 3 extends to the west and south of The Rookery and through the village of Marston Moretaine.





MOVEMENT & CONNECTIONS

KEY

-  Project Site Boundary
-  M1 Motorway
-  Railway Line
-  Milton Keynes Boundary Walk
-  John Bunyan Trail
-  Greensand Ridge Walk
-  Bedfordshire Cycle Route 03
-  National Cycle Route 51





2.9 Wider Context: Landscape

2.9.1. Policy Context

Green Infrastructure (GI) policy relating to the Project has historically been driven by the East of England Plan (EoEP), and promoted in the Bedfordshire and Luton Strategic Infrastructure Plan (2007) and the Forest of Marston Vale Plan (2000) policy objectives. The EoEP no longer forms part of the development plan but its aspirations and objectives are referred to in this DAS as the EoEP informed the adoption of existing development plan policies relating to GI. Emerging development plan policies, for example in the Central Bedfordshire Local Plan 2015-2035 (Draft Plan – 2017), seek to continue support for improved GI.

2.9.2. The retention, protection and enhancement of GI assets was regarded as vital to ensure that major planned growth within the region will be sustainable. A summary of relevant GI planning policy is provided below and within the Planning Statement (Document Reference 10.1) accompanying the Application.

2.9.3. Existing Green Infrastructure Provision

Existing strategic and local GI assets within the Marston Vale comprise:

- Open water bodies created within former quarry pits which have both recreational and ecological value (designated as County Wildlife Sites);
- Natural and semi-natural habitat for wildlife including large areas of woodland, parkland and remnant heathland;

- A network of hedgerows and watercourses, including the Elstow Brook;
- The Marston Vale Millennium Country Park;
- Historic parks and gardens and historic landscapes including Ampthill Park, a Capability Brown designed parkland and the biggest expanse of acid grassland in the County;
- Designated and undesignated cultural heritage assets which include Ampthill Castle and Houghton House (both Scheduled Monuments) and Stewartby Chimneys (Grade II Listed);
- A network of public rights of way, cycleways and other recreational routes; and
- A local, regional and national railway network.

2.9.4. Green Infrastructure Initiatives

The Marston Vale Trust's Forest Plan is the key local delivery document for GI across the Marston Vale. Working with local communities, government and businesses, the 40-year vision (now into its 10th year) is to deliver environmental regeneration that will act as a catalyst to social and economic regeneration of the area, whilst providing major recreation, landscape, biodiversity, cultural heritage and quality of life benefits.

2.9.5. Major potential development in the area, which includes the Millbrook Project, will be expected to contribute to delivering the Trust's policy objectives.

2.9.6. There are major GI initiatives for wetland creation in relation to the proposed Milton Keynes to Bedford Waterway Park (see below) and restored brick pits together with significant new areas of accessible green space and woodland and other habitat linkages between the existing ancient woodlands on the wooded slopes surrounding the Vale.

2.9.7. The Milton Keynes and Bedford Waterway comprises construction of a broad waterway which will link the Grand Union Canal in Milton Keynes to the River Great Ouse in Bedford through a series of waterway parks. The waterway will provide the opportunity to enhance strategic bridleway, cycle and footpath links and will create natural and semi-natural habitat for wildlife.





2.9.8. The Project responds to delivery of these GI initiatives by recognising the changing context of the site and the key role The Rookery plays in securing repair and enhancement to the rights of way network east of the Forest Centre linking the Millennium Country Park to the Greensand Ridge, planting of woodland and provision towards the Trust Fund proposed by Covanta to further support the objectives of the Forest of Marston Vale.





LANDSCAPE DIAGRAM

KEY

-  Project Site Boundary
-  Strategic Green Infrastructure Network
-  Railway Line
-  Railway Station
-  Watercourses
-  Open Water
-  Proposed Canal Route



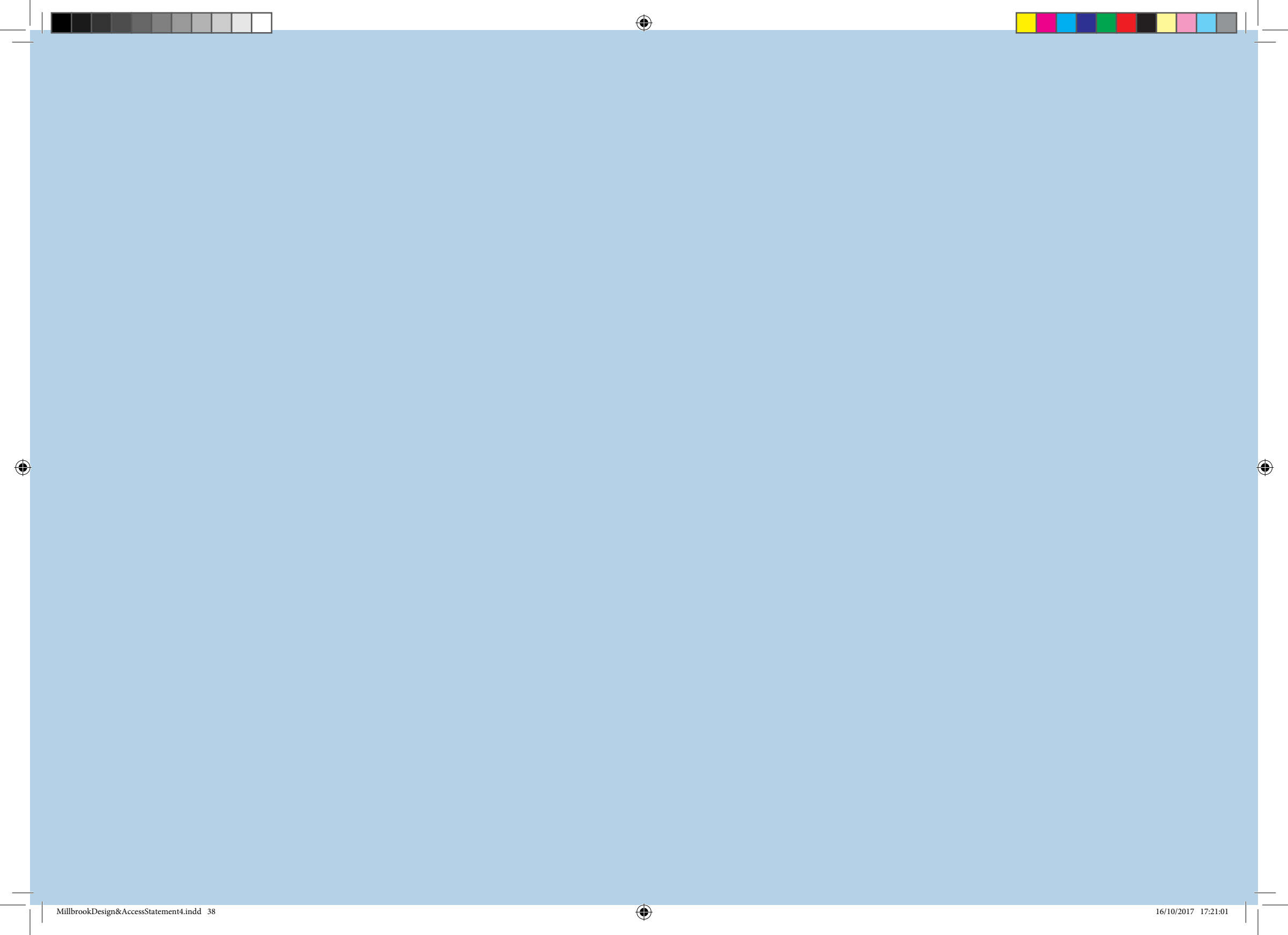



03. Site Setting





3.1 Site Setting

3.1.1. Overview

This chapter considers the more immediate context of the Project Site itself in further detail under the headings of:

- **Built form and visual structure;**
- **Movement and connections; and**
- **Landscape.**

3.1.2. These are described in detail over the following pages and illustrated in the plan opposite.

3.1.3. A number of factors relating to the above headings will be identified at this spatial scale and will be taken forward to influence the key design principles for the Project described in Chapter 4.

3.1.4. Project Site Description

The Power Generation Plant Site and part of the Gas and Electrical Connections would be situated on land within a former clay pits known as 'The Rookery' and more specifically Rookery South Pit. The Generating Equipment Site plot is a rectangular shaped site of approximately 4 ha and is shown outlined on the plan opposite.

3.1.5. The immediate context for the proposed Power Generation Plant is the post-industrial landscape within the pit itself and the mature rural landscape out

with the pit. The pit itself is sunken and on a ground plane 15 m lower than the surrounding ridge and landscape beyond.

3.1.6. Additional factors that require consideration to influence the key design principles of this Project are:

- A separate but complementary restoration project is underway and on-going in respect of proposals to restore both Rookery North and Rookery South Pits. This is referred to as the Low Level Restoration Scheme (LLRS). The LLRS is focused predominantly on Rookery South Pit and will include slope stabilisation works; establishment of woodland planting; establishment of grassland and; the establishment of an attenuation pond and associated drainage channels.
- The Covanta RRF, which comprises and Energy from Waste (EfW) and Material Recovery Facility (MRF). Although the Covanta RRF has statutory consents the facility has not yet been built, though elements of the LLRS program are underway.
- This Design and Access Statement not only takes cognisance of all the above but also has been set out to recognise and respond to the two separate scenarios: one where the Covanta RRF is complete and operational and the other where it may not be and therefore the Project is built and operational without the Covanta RRF.



OUTLINE PLAN FOR LLRS

KEY

- Project Site Boundary
-  Railway Station
-  Railway Line





3.2 Site Setting : Movement & Connections

3.2.1. Road access

Road access to the Generating Equipment Site is currently from the north near Stewartby via the A421, Bedford Road and Green Lane. There is a junction on Green Lane leading to an access track which extends southwards into Rookery South Pit and the Generating Equipment Site.

3.2.2. The Gas and Electrical Connections would either be accessed via the route described in 3.2.1 above or from the A421, northwards along the A5141, westwards then southwards for approximately 7 km along the B530 (referred to variously along its route as Amphill Road / Hardwick Road / Bedford Road / Hazelwood Lane) to Millbrook Road, Houghton Lane and (in the case of the Electrical Connection) Station Lane.

3.2.3. Nearby roads include the A421 which is approximately 2 km to the west and the B530 which lies to the east of the Project Site. The A421 connects directly to Junction 13 of the M1 Motorway which is approximately 5.6 km to the south east of the Project Site. Furthermore the Midland Mainline Railway and Marston Vale Line border the Power Generation Plant Site to the east and west respectively.

3.2.4. Railway

The Marston Vale Line runs adjacent to the Project Site. There are a number of local stations along the line to the west, including those at Lidlington, Millbrook, Stewartby and Kempston Hardwick. The

line forms part of the east west rail proposal, which seeks to provide a high speed rail freight route from Bristol to Felixstowe via Oxford and Cambridge.

3.2.5. The Marston Vale is slightly elevated above the Project Site, with a near continuous narrow tree and scrub belt separating. There are some maturing trees straddling the fence line.

3.2.6. Rights of Way

There are no Public Rights of Way within the Power Generation Plant Site. Footpaths within close proximity to the Power Generation Plant Site:

- To the north-west of the Power Generation Plant Site FP72 provides a leisure footpath around the Stewartby Lake. In order to form an access between Stewartby and FP72, there is a footpath link to Green Lane 160m west of the railway crossing.
- To the west of Stewartby Lake, there is a footpath link to Bedford Road, via FP19. This joins Bedford Road within a national speed limit zone, where no footway is present.

3.2.7. A number of Permissive Footpaths will be delivered within the Rookery as part of the LLRS, but their precise location is not known at present.



Marston Vale Train Line



A421 at Stewartby at Green Lane access





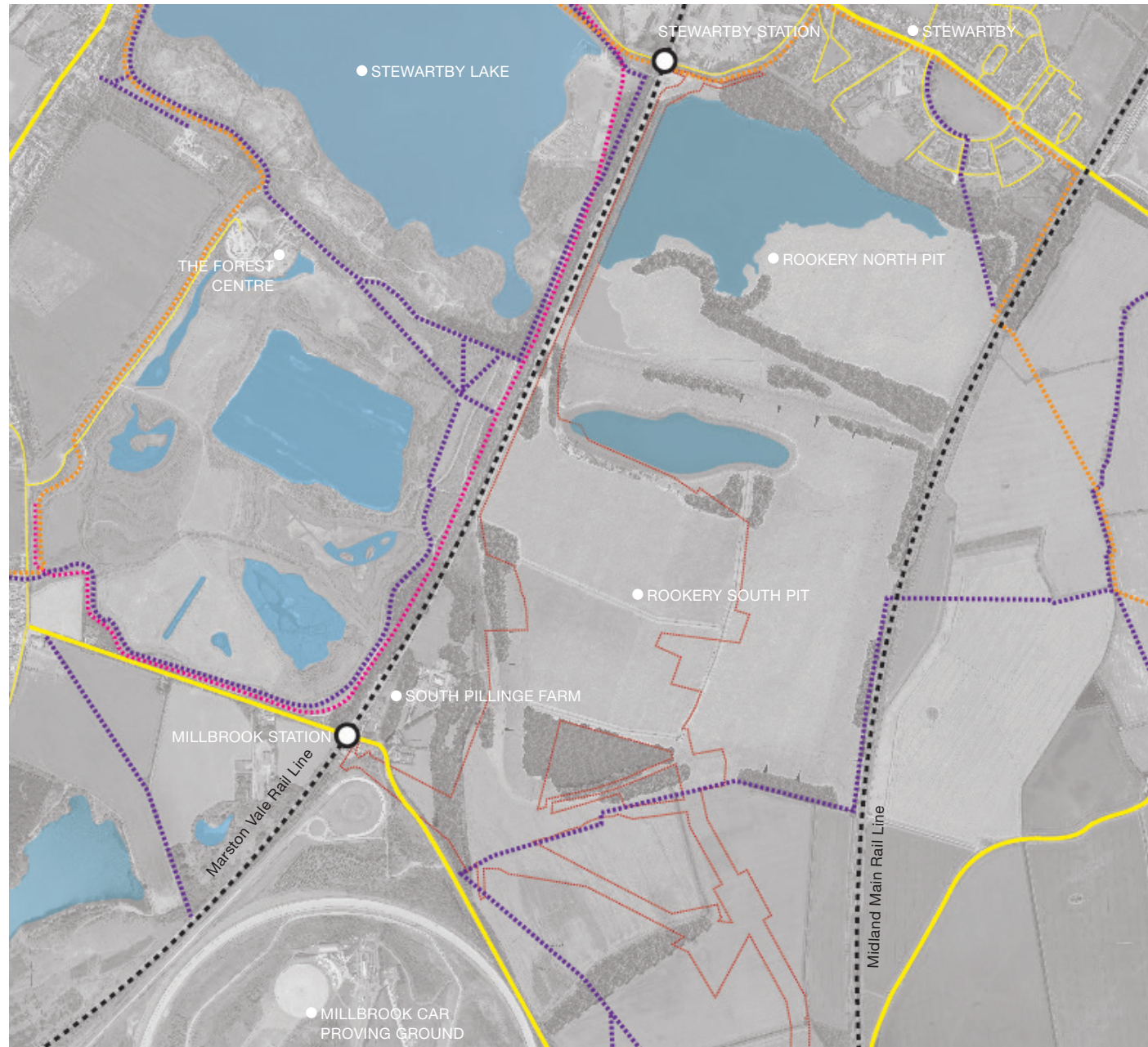





Entrance to Green lane access track.



MOVEMENT & CONNECTIONS

KEY

-  Project Site Boundary
-  Roads
-  Railway Lines
-  Railway Stations
-  Footpath
-  National Trail
-  Non Traffic Cycle Routes
-  Watercourse / Water body





3.3 Site Setting : Landscape

- 3.3.1. Substantial areas of land around Stewartby, including the Rookery South Pit, have been previously worked for clay that was used in Stewartby Brickworks until it closed in 2008. To the north of The Rookery there remain some buildings associated with the former Stewartby Brick Works, including four chimneys which are now listed structures. Following clay extraction, these former clay working sites have been restored (to varying levels of completion) by different means (including the disposal of waste) and for different uses, including water based recreation and commercial uses.
- 3.3.2. Furthermore, significant regeneration and development is allocated for the Northern Marston Vale Growth Area, in which the Project Site is located. This will result in further change within the landscape, not least represented by substantial residential and employment development such as in the nearby settlements of Marston Moretaine and Stewartby.
- 3.3.3. There are overhead power lines that run west to east south of Rookery South Pit as well as a number of existing public footpaths located in and around the Project Site, linking it to the wider Marston Vale. However there is limited public access to Rookery South Pit itself until the permissive footpaths of the LLRS are completed.

3.3.4. The Millbrook watercourse flows in a northerly direction along the western flank of Rookery South Pit whilst a tributary watercourse, passing to the south of Rookery South Pit within the Project Site, joins Millbrook in the vicinity of South Pilling Farm.



Section Lines Key Map - Existing Project Site



View from Millbrook looking north, showing electrical pylons and Stewartby Brickwork towers.



View looking southwest from southern extent of Rookery South Pit showing electrical pylons.



Panorama looking south from Rookery South Pit.



Section C-C

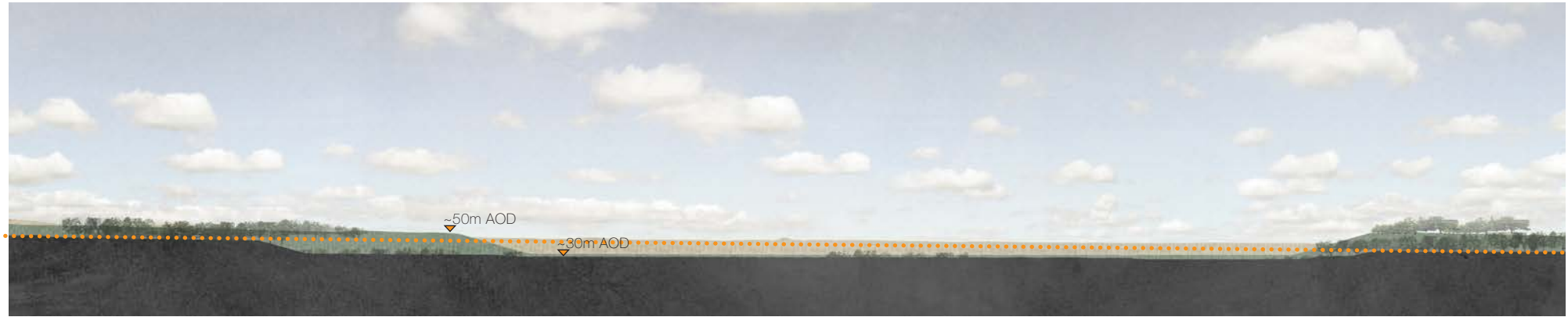

The Rookery South Pit

Section D-D



The Rookery South Pit

Existing sections through Rookery South Pit indicating the level difference between the pit banks and pit.





3.4 Site Setting : The Rookery & Immediate Setting

- 3.4.1. A separate but complementary restoration project is proposed and on-going in respect of proposals to restore both Rookery North and Rookery South Pits. This will provide for implementation of what is referred to as the LLRS. The Project design proposals have been developed on the basis of these infrastructure works being completed. Therefore any works associated with the Project that impinge on the LLRS such as laying the underground cable for the Electrical Connection or constructing the Gas Connection will also propose reinstatement where necessary.
- 3.4.2. The LLRS proposals have Statutory Consents and works are currently underway. The overarching objective of the work is to fulfil the requirements of a Review of Old Minerals Permissions (ROMP).
- 3.4.3. The LLRS proposals have been developed with the objective of restoring the former clay workings at The Rookery to enable a low intensity agricultural end use with particular attention to biodiversity and landscape enhancement. The restoration scheme is focused predominantly on Rookery South Pit and will include slope stabilisation works; establishment of woodland planting; establishment of grassland and; the establishment of an attenuation pond and associated drainage channels. Once restored, the base of Rookery South will form the platform for the Project. The LLRS works being carried out in Rookery North Pit are focusing on nature conservation. These include lowering lake water levels to establish greater areas of wetland, localised slope stability / erosion control works, limited woodland planting, and the introduction of footpaths.

- 3.4.4. The design proposals for the Project should have a strong landscape and ecological rationale – taking cognisance and respecting/considering the existing and mature landscaping but also the LLRS for The Rookery.
- 3.4.5. The Rookery comprises two large clay pits, Rookery North Pit and Rookery South Pit, separated by an east-west spine of unexcavated clay, covering an area of approximately 210ha. The Project Site comprises approximately 48ha in total with the Generating Equipment Site and Substation taking up 10ha of the south western quadrant of Rookery South Pit.
- 3.4.6. The Rookery has a long history of clay working, supplying Oxford Clay for brick manufacture at the London Brick Company works at Stewartby. The winning and working of clay was originally permitted in 1952. Since then, clay extraction has taken place over the majority of the permitted area at The Rookery. Some reserves remain, being largely confined to land within the south western corner of Rookery South.
- 3.4.7. The existing physical characteristics of both Rookery North and Rookery South Pits, which are described in the following paragraphs, will be subject to change as the approved LLRS works are implemented. These works would return The Rookery to low intensity agricultural land (in large part) and will provide additional ecological and amenity benefits.

3.4.8. Rookery North Pit

Rookery North Pit is approximately 70ha in area and presently encompasses a deep lake in the central / western area fringed by extensive stands of reed-swamp which extend into a coarse and relatively species-poor grassland. There is a backfilled area in the east and south east part of Rookery North comprised largely of mineral (clay) waste deposited under a Waste Management Licence. The base of the flooded pit sits approximately 20m below the surrounding ground level at circa 17.5m AOD at its deepest, with a berm along the western edge at circa 32m AOD. The smaller water body located at the south western corner of Rookery North has a base level of 28m AOD. A continuous belt of trees along the northern boundary provides a buffer between Rookery North Pit and Green Lane, Stewartby. The elevated portions of Rookery North Pit include species-poor neutral grassland, immature broadleaved plantation woodlands, scattered broadleaved trees and shrubs, and both dry and seasonally-wet ruderal communities. The North Pit abuts Green Lane and Stewartby.

- 3.4.9. Rookery North Pit supports an assemblage of protected species and species groups, most notably great crested newts, aquatic and terrestrial invertebrate assemblages and stonewort communities. In addition, several species of bat forage extensively over the waterbodies and use the linear vegetated features for commuting.





Plan showing Rookery North & South Pits on completion of the LLRS works.





3.4 Site Setting : The Rookery & Immediate Setting

3.4.10. Under the LLRS the Rookery North Pit lake will be partially drained to improve lake-edge habitat and areas of habitat created as translocation habitat for protected species removed as part of the lake draining works in Rookery South Pit.

3.4.11. Rookery South Pit

Rookery South Pit is approximately 95 ha in area. The majority of the pit is approximately 10-24m below surrounding ground levels and is currently bounded by steep clay banks, which have a stepped profile to the west and southeast corner with instability observed in many areas principally to the south, east and northeast of the pit. The instability of the clay banks is to be addressed via the LLRS, as explained further below. The base of the pit comprises large, ephemeral waterbodies which are fringed by extensive stands of reed-swamp and coarse, relatively species-poor, grassland. The land around the periphery of the pit that remains at the original ground level, approximately 42m AOD, is primarily grassland with scattered scrub and maturing woodland to the southeast.

3.4.12. In addition, there are seasonally parched areas of bare ground (predominantly on the exposed slopes) which support a ruderal botanical community. The Pit is accessed from Green Lane by a track, some 700m long, which extends along the western boundary of the Project Site adjacent and parallel to the Marston Vale Line.

3.4.13. The Rookery, like many other remnant clay pits in the area, is designated as a County Wildlife Site.

3.4.14. Low Level Restoration Scheme

Under the LLRS proposals, the base level of Rookery South Pit and the existing bank profiles will be altered with slacker slopes and a re-graded pit base including drainage ditches draining to an attenuation pond including access tracks extending down the pit embankment face. Protected species have been translocated to Rookery North Pit and the receptor site at Stewartby Way 2.

3.4.15. The LLRS is being implemented on a phased basis and the Project design proposals are developed on the basis that those works will be substantially completed.

The key aspects of the LLRS strategy are outlined in the diagram below.





KEY

- 01 Existing Woodland
- 02 Proposed Woodland Mix 1
- 03 Proposed Woodland Mix 2
- 04 Proposed Woodland Mix 3
- 05 Proposed Grass Mix 1
- 06 Proposed Grass Mix 2
- 07 Proposed Native Hedgerow
- 08 Proposed Pond
- 09 Proposed Drainage Ditch

Plan showing Rookery North & South Pits on completion of the LLRS works.



3.5 Site Setting : Covanta Resource Recovery Facility

3.5.1. Further site setting considerations for the Project is the Covanta RRF, on an immediately adjacent site. This Design and Access Statement document in the following chapters considers not only the site setting at the Rookery South Pit with the Covanta RRF as a completed project with associated landscape design but also the separate scenario where the Covanta RRF and associated landscape design has not proceeded.

3.5.2. The main components of the Project are an EFW Facility with an average gross electrical output of 65 Mega Watts (MWe) Facility, and a post treatment MRF to recover/recycle bottom ash and metals. The nominal capacity of the EFW Facility is 585,000 tonnes per year of mixed residual municipal, commercial and industrial waste.

3.5.3. The Project obtained the necessary statutory consents in 2011 and is proposed as an important source of renewable energy. Sufficient electricity could be generated to serve the needs of 82,500 homes.



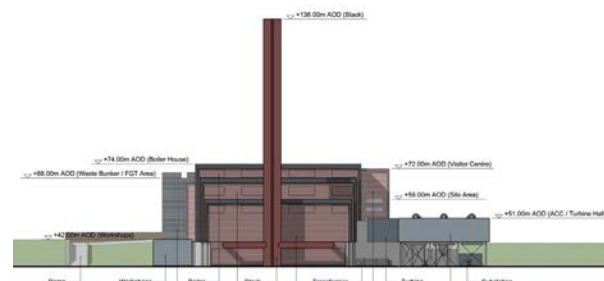
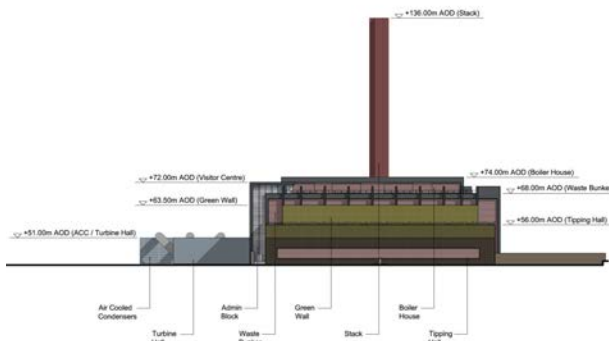
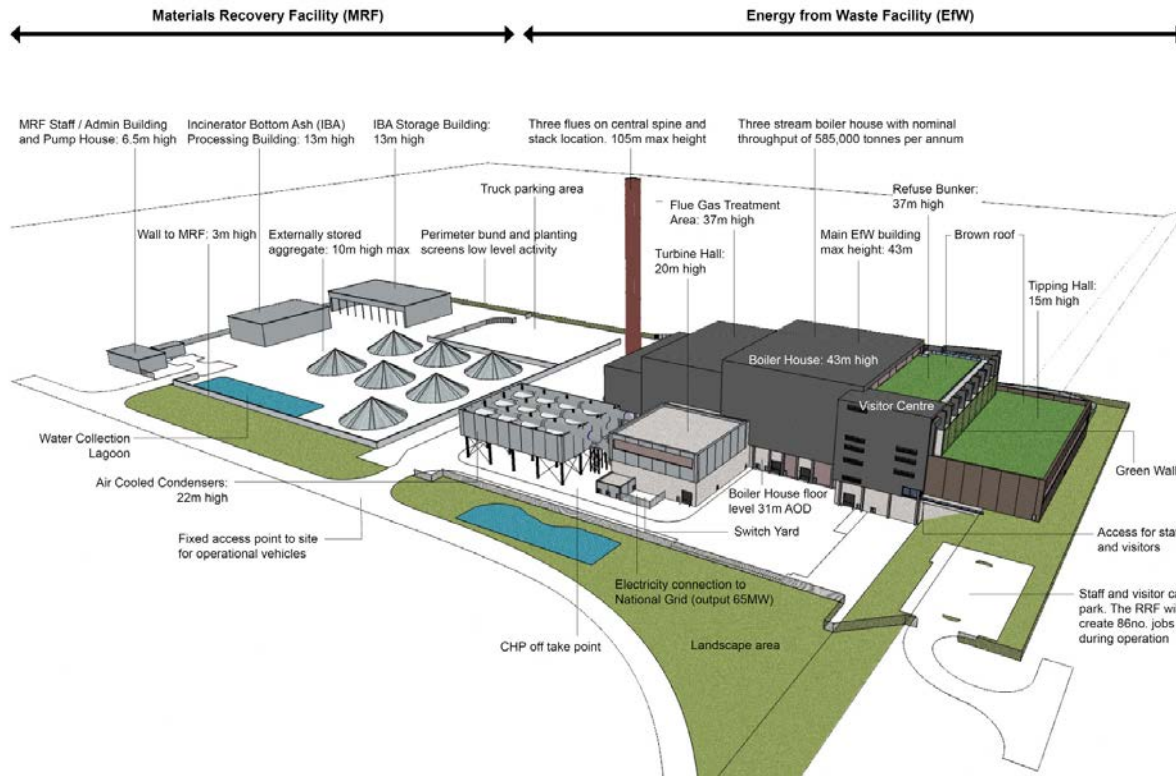



3.5 Site Setting : Covanta Resource Recovery Facility Sections

3.5.4. The Covanta RRF comprises a series of buildings associated with the EfW Facility and MRF. It also includes a new access road and upgraded junction from Green Lane; extensive landscape works (significantly increasing the extent of tree planting around Rookery South); ecological habitat creation; improvements to the rights of way network; provision of a visitor interpretation / education centre within the main EfW Facility building; and underground electricity grid connection infrastructure. The nature of these elements has been informed by extensive design work and a detailed understanding of the surrounding environment so as to ensure successful integration of the Covanta RRF into the Marston Vale.

3.5.5. The sectional drawing studies on the adjacent page taken through the Rookery South Pit indicate the Covanta RRF and its relationship to upper banks of the pit. The top section is looking South and the bottom section is looking West towards Marston Vale Train Line. The sections indicate clearly the ground plane level of the RRF some 25m below the perimeter banks and this level difference would assist in mitigating any visual impact.





Section C-C

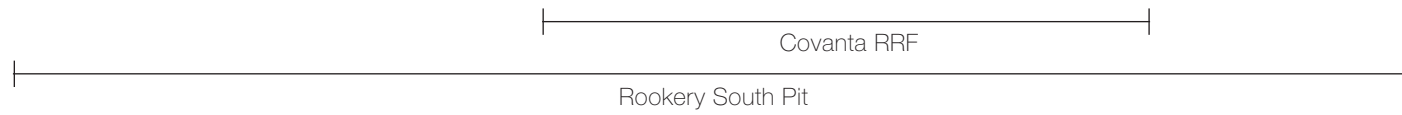

Section D-D







04. Design Response





4.1 Design Response : Overview

4.1.1. This Chapter sets out the design criteria developed in response to the emerging principles identified in Chapter 3. The Design Principles have been developed under the following headings again:

- **Built Form and Visual Structure;**
- **Movement and Connections;**
- **Landscape**

4.1.2. These principles set the brief for the Indicative Design Proposals which are described in Chapter 5 of this statement.

4.1.3. The following tables demonstrate how the design principles form the framework for the Project Site in terms of the three headings.

4.1.4. Additional factors influencing the key design principles include the following:

- A separate but complementary restoration project is ongoing at the Rookery, referred to as the LLRS. The restoration scheme is focused predominantly on Rookery South Pit and will include slope stabilisation works; establishment of woodland planting; establishment of grassland and; the establishment of an attenuation pond and associated drainage channels.

- The Covanta RRF, comprising an EfW facility and MRF. Although the RRF has statutory consents the facility has not yet been built.
- This Design and Access Statement in the following section takes cognisance of all the above, and has been set out to recognise and respond to two separate scenarios. One where the Covanta RRF is complete and operational and the other where it may not be build: the second scenario therefore only considers the Project in isolation.





4.2 Design Response : Design Principles

ANALYSIS



DESIGN PRINCIPLE



MILLBROOK POWER PRINCIPLE

Built Form, Uses & Activities

01 Specify or design items of larger plant with consideration to their visual appearance in the local and wider landscape.

The proposed buildings, structures and perimeter security fencing shall be of high quality design. Materials used for cladding shall above all need to be durable and functional, as appropriate for 25 years operation in a power station environment.

The design should be such that it minimises visual impact and blends with the background and foreground as far as possible, with recessive colouring.

Consideration should be given to cladding in scale & grades of colour appropriate to the local surrounding backdrop, to minimise visibility in long distance views.

Stack heights shall be minimised to 32.5m - 35m height and will not be illuminated or contain signage unless for safety/ operational requirements.

Built Form, Uses & Activities

02 Lighting shall be appropriate to the local context and avoid lighting impacts upon identified habitats, neighbouring occupiers, and the wider landscape.

The overarching philosophy underpinning the design of the lighting for the project is as far as possible, to maintain a 'dark' site. Only critical light sources such as emergency exit illumination and security lighting at low level will remain on during the night.

The scheme of lighting should minimise detrimental visual and environmental impacts. This would be achieved through appropriate placing, directionality, and technology of lighting and a preference for a greater number of lower level building mounted lamps.

Built Form, Uses & Activities

03 Stack should be designed at a height which causes minimum visual impact whilst also allowing for adequate dispersion of stack emissions.

The height of all plant should be minimised. The design of the project utilises technology (OCGCT) that allows a significant reduction in stack height compared to other technology types. Stack shall be between 32.5 m – 35m height and shall not be illuminated or contain signage or branding unless necessary for a recognised safety / operational requirement.



ANALYSIS



DESIGN PRINCIPLE



MILLBROOK POWER PRINCIPLE

Built Form, Uses & Activities

04

The Power Generation Plant Site shall be laid out and, where possible, maintained in a safe and attractive manner and which supports a positive public perception of the operation.

The main entrance and other permanent accesses shall have high quality branded signage so that visitors and passers-by can understand the use of the site.

Vehicle parking, storage areas and smaller structures shall be laid out and screened so as to minimise visual clutter and improve the safety and perception of safety of the site operation.

The Construction Environment Management Plan (CEMP) shall include measures for the maintenance of a tidy and contained site compound during construction.

Built Form, Uses & Activities

05

The site layout shall consider the need to minimise noise and vibration impacts on the wider area.

Detailed design shall ensure that noise is mitigated as far as possible, through the Project Site layout and consideration of the orientation of plant items associated with higher sound power levels. Inherently quiet plant items shall be selected wherever practicable. Consideration shall be given to the use of silencers and housing plant items in acoustic enclosures where practicable.

Noisy elements of the plant shall be located away from the nearest noise sensitive receptor (South Pillinge Farm). The Stack would be located at the eastern side of the Generating Equipment Site, furthest away from the farm property.

Built Form, Uses & Activities

06

Consideration shall be given to the most appropriate choice of materials. Materials should be agreed with the local planning authority.

Materials chosen shall be robust, high quality and cost-effective. The architectural design, use of cladding materials and colours of the buildings and structures on the Rookery South Pit site shall be designed to reduce glare and blend into the surrounding landscape.

Built Form, Uses & Activities

07

Site layout and location of Substation to minimise impact and be compliant.

Substation design, layout, and related access must be compliant with NGET requirements

The Substation shall be been located in close proximity (within 500m) of the existing 400kV overhead line to reduce impacts associated with the construction of the Electrical Connection.

Design Principles



ANALYSIS



DESIGN PRINCIPLE



MILLBROOK POWER PRINCIPLE

Built Form, Uses & Activities

08 Site layout of plant will take account of neighbouring land and property uses.

The Project Site layout and landscaping proposals shall be designed to take account of the LLRS and Covanta RRF.

The siting and location of the Substation in Rookery South Pit shall avoid sterilisation of farm land. The AGI shall be sited and located to minimise sterilisation of farm land.

Built Form, Uses & Activities

09 Site layout of larger plant with consideration of their visual appearance in the local and wider landscape.

Siting the Stack and larger plant in a centralised location within the pit maximises the ability to provide and achieve visual mitigation from landscape screening positioned on the upper bank of the pit, at the pit boundary.

Siting more visually prominent plant in a centralised location will take advantage of the lowest ground plane levels within the pit and opportunities for natural screening to be provided by existing and proposed landscape at the perimeter of the site on the upper bank of the pit.



ANALYSIS



DESIGN PRINCIPLE



MILLBROOK POWER PRINCIPLE

Movement, Connections & Access

01 Design safety and operation of access roads and internal site roads.

Ensure that access routes and internal road layouts are designed to allow safe and efficient operation. Substation and plant layout shall be designed to allow for safe and efficient operation including adequate access for vehicles and on-site workers. Vehicle parking shall be adequate for workers and visitors to the site and shall include a fully accessible space for a disabled worker or visitor, and be proximate to buildings they serve.

Movement, Connections & Access

02 Ensure that access routes are appropriate for the vehicles that shall use them during site construction and operation.

Re-use existing entrances and routes to the site providing adequate operational and safety access. Where removal of access points are required for construction works any roadways and footpaths will be reinstated to adequate and appropriate standards.

Design Principles



ANALYSIS



DESIGN PRINCIPLE



MILLBROOK POWER PRINCIPLE

Landscape, Environment & Ecology

01 Minimise impacts on existing habitats and species within the site.

The design of landscape planting should enhance the area's biodiversity through: the retention of existing trees & bushes; the planting of belts of broadleaved woodland to increase the amount of natural green landscape in the area; the reinstatement of planting where possible and appropriate; and careful management of soils.

The routing and installation of the utility connections should minimise the impact on existing landscape and ecological features and the sterilisation of land – careful routing to be used where possible.

Landscape, Environment & Ecology

02 Reinstatement the routes of the Gas and Electrical Connections with appropriate planting for their wider and local landscape and habitat setting, taking into account the need to avoid damage from roots.

Soft planting along connection routes should be reinstated in accordance with soil handling and reinstatement strategy.

Where existing trees or soft planting are lost, and cannot be replaced through tree planting due to restrictions above and adjacent to the pipeline or cable, appropriate planting should be reinstated to retain the linear feature and provide connectivity for wildlife.

Where inside the permanent easement of the Gas and Electrical Connections, only shallow-rooting tree/shrub species should be used.

Any existing woodland, LLRS or Covanta RRF planting removed/lost due to Electrical Connections shall be replaced with appropriate native species with a view towards not eroding or undermining existing or already planned screening objectives.

Landscape, Environment & Ecology

03 The use of soft landscaping should be maximised within the Power Generation Plant Site where safety and operational considerations allow.

Amenity planting should be used to enhance and reinforce the character of the surrounding area.

The design of perimeter security fencing and its alignment inside boundary structure planting should provide a 'soft' edge to the industrial development, and connect with adjacent trees and vegetation.



ANALYSIS



DESIGN PRINCIPLE



MILLBROOK POWER PRINCIPLE

Landscape, Environment & Ecology

04 A landscaping scheme should be developed that ensures the Project Site is designed and landscaped to complement the local and wider setting, and project distant views.

Good quality trees shall be retained.

The approach to screen planting should seek to improve the amenity of the area and enhance biodiversity, and be carried out in accordance with the Landscape and Ecology Mitigation and Management Strategy (LEMMS). Belts of trees along the southern edges of the site should be planted. The southern edge tree planting will link with the already mature adjacent plantation at the southern edge of the Rookery Pit.

Reinstated and designed landscaping along southern boundary shall take account of and respect the public right of way.

Planting shall consist of appropriate native species of trees and hedgerows.

Screen planting (hedgerows or woodland) will match and complement existing species and be integrated to mitigate visual impact on views.

Planting proposals to augment and support existing natural hedgerows and woodland with an intention to assist visual screening properties.

Landscape, Environment & Ecology

05 The layout and landscaping design to take cognisance of historical and established topography and landscape pattern.

Landscaping proposals should be sympathetic to the character of the landscape, in their alignment, scale and composition.

Landscape, Environment & Ecology

06 Consideration of species for planting to be appropriate to location.

Existing hedgerows along the access road approach to be retained as an important bat corridor. Any length of hedgerow lost to be replaced with appropriate native species.

Retain and reinforce boundary tree planting where trees are found to be of good/retainable quality.

Landscape, Environment & Ecology

07 The design shall take into account the provision of robust fencing around the site to ensure safety of the site.

The design of perimeter security fencing and its alignment inside boundary structure planting shall provide a 'soft' edge to the industrial development, and connect with adjacent trees and vegetation, consistent with appropriate security arrangements.





ANALYSIS



DESIGN PRINCIPLE



MILLBROOK POWER PRINCIPLE

Sustainability

01 Wider environmental considerations.

Research and careful consideration during the site selection process at the Project outset in order to identify sites where the collocation of the NETS and gas National Transmission System feeder pipelines occurred, thus ensuring the least environmental disruption and minimising Project land take.

Commitment to the use of Dry Low NOx abatement technology to reduce water use requirements on Project Site.

Opportunity to enhance and introduce biodiversity through landscaping and ecological mitigation measures, such as through the creation of ponds.

The Electrical Connection shall be undergrounded where possible to minimise visual impact, avoiding siting plant on agricultural land.

The design proposals shall take account of the character of the area generally, including its industrial heritage and the rural and agricultural nature of the landscape to the south of the project site.





4.3 Design Response : Initial Design Approach

4.3.1. At the outset of the Project, a number of different engineering and plant options were considered. The initial design response in absence of a finalised engineering solution was to consider (as is typical of many similar NSIP projects of this nature) a development "envelope" enclosure for the various plant components, not dissimilar to the Covanta RRF. This approach would provide a degree of flexibility to arrange the components with the Order Limits. It would also allow engineering optioneering to continue and broad concepts for visual screening to be developed.

4.3.2. The design concept graphics adjacent indicate the initial approach adopted to address and minimise the visual impact of an enclosure within an integrated design landscape to mitigate/filter views. The architectural design intention visually was that the building colour, materiality and texture would be informed by features in the surrounding and distance landscape.

4.3.3. Sheppard Robson carried out a detailed study of the landscape character not only in the near vicinity of the Project Site, but also in a wider

study area taking in Millbrook, Stewartby, and Ampthill, and stretching out further in all directions to investigate and more closely understand the texture and mix of colour and tones in the environment that could then be translated into the enclosure elevations. The mixture of tones and colours would also have to be representative, as much as possible, of the changing seasons in and around the site. The graphics (to the right) demonstrate in more detail how this analysis translates into colour contrast and tones.

4.3.4. Various surrounding and long distance photographs were taken, then broken down into a pixelation of the representative colours. From this, the predominant and highlight colours were established, along with matching tones that could then be tested in the façade cladding of the proposed enclosure. Not only colour combinations were investigated, but also the orientation of panels, and size of panels to achieve a scale and harmony with the existing backdrop landscape.





View of proposed site.



Building cladding panels arrangement as response to horizontal strata in the landscape.



Pixelated image of surrounding landscape translated into colour tones.



Defined horizontality on building elevation in response to horizontal landscape strata & backdrop.



Colour palette - horizontal rural landscape translated into zones of cladding.



Building cladding panels as response to horizontal landscape backdrop of sky.





4.4 Design Response : Built Form

4.4.1. As the continual review of various engineering/ plant options progressed through the early design development stages, the necessity for design flexibility became a primary consideration. As a consequence of this, the decision was taken to pursue a 'Rochdale Envelope' type engineering solution approach. This approach requires that the various plant and buildings are strategically planned out on the Project Site and negate the requirement to house everything in an envelope enclosure. The various plant as indicated on the adjacent page range in scale and type from Gas Turbine Generator and Stack to water tanks and other small scale buildings.

4.4.2. This site planning of the various items of plant and buildings has to ensure efficient and safe working arrangements and direct routes for Gas and Electrical Connections with minimum disruption. At the same time, the strategic siting of the various different items of plant and buildings can be planned to address a number of other environmental and visual impact type criteria. As the various plant and buildings are planned and separated out on the site as opposed to the large envelope enclosure approach, the visual impact is reduced immediately and the ability to address any other key issues such as noise sensitive receptors is improved. Interrupted views towards the site and beyond can be minimised by this separating out and careful planning of the larger pieces of engineering plant such as gas turbine and stack. Along with this, the aligning of taller elements like the Stack will immediately reduce the visual impact from key view corridors.

4.4.3. The design concept intention developed for the 'envelope enclosure' approach on the previous pages would be maintained but then adopted for the various buildings and engineering plant components around the site. The colour response would take reference from the immediate rural surroundings and more distant landscape context. From this sampling, the horizontal strata and bands of landscape colour are established, taken from foreground all the way to the backdrop of the distant hills and sky.

4.4.4. Detailed studies of the landscape were undertaken as indicated on the following pages. These studies were then translated into elevational studies. The mixture of tones would also be representative of changing seasons in and around the wider area of Stewartby, Millbrook, and Ampthill.

4.4.5. The graphics demonstrate in more detail how this analysis translates into colour contrast and tones. Particular photographs were taken from within the Project Site looking out to the distant relatively flat planes which are only broken by trees, bushes and hedgerows then broken this into a pixilation of the colours. From these colours along with colour matching, horizontal strata were established that can be applied to the various plant components from base to top.





Building or Structure	Maximum height (metres)	Maximum length (metres)	Maximum width (metres)
Gas turbine Generator (including gas turbine, generator, air inlet filter house, air inlet duct, exhaust diffuser, and auxiliaries such as lube oil system, air dryers, fuel gas filter package, instrument air system, compressor washing)	27	50	40
Exhaust gas emission flue stack	35	12	12
Control room/office/ workshop	07	45	25
Emergency Generator	06	13	05
Raw/fire water tank	15	15	15
Demineralised water tank	05	05	05
Gas receiving station (including compression station, emergency generator, Joule-Thompson boilers and other auxiliary control cabinets)	10	70	50
Fin Fan Cooler(s)	10	28	14
Transformer compound (including generator step up transformer, unit and other transformers, overhead line gantry and associated equipment.)	15	65	60
Gatehouse	4.5	09	08
Above Ground Installation	03	85	35
Pipeline inspection gauge facility	03	35	30
Minimum offtake connection	03	35	35
Substation (including the auxiliary building)	14	200	150
Sealing End Compounds	17	45	35
Transmission tower	49	40	30
Temporary towers or masts**	55	47	32

(metres above existing site level of approximately 31.5 metres AOD unless otherwise stated)

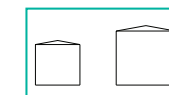
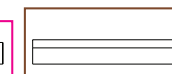
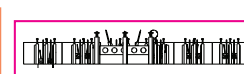
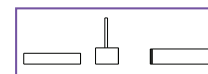
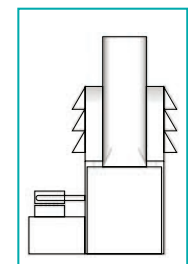
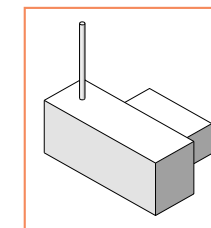
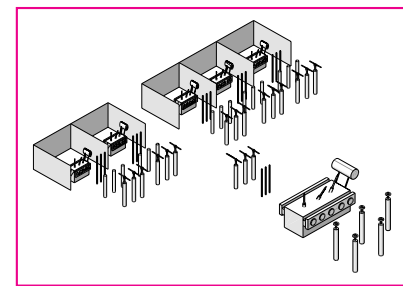
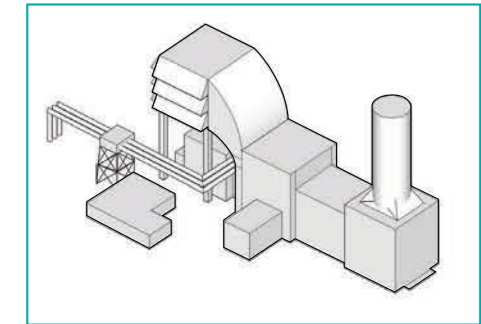
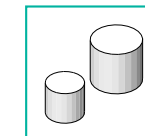
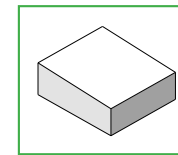
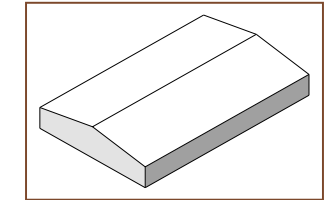
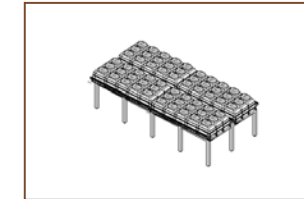
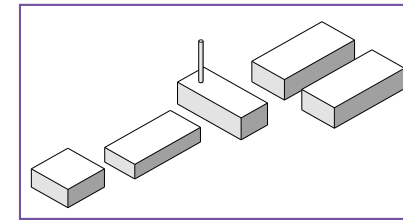



4.5 Design Response : Context

- 4.5.1. The Design Response diagrams on the following pages relate to the previous series of principles (Section 4.2 Design Principles) and demonstrate graphically how they may be addressed.
- 4.5.2. The sketch diagrams on this page and the next demonstrate initially the intentions with respect to Project Site layout and how the orientation and plan arrangement of the plant and buildings can be set out to minimise visual impact from exposed viewpoints. The layout at the same time has to be efficient and workable in terms of Gas and Electrical Connections to create minimum impact.
- 4.5.3. The location within the pit takes advantage of the lowest ground plain levels available to assist in mitigation from key visual receptors.
- 4.5.4. Noisy elements of the plant shall be located furthest from the noise sensitive receptors (South Pilling Farm). Site arrangement locates the stacks at the eastern side, furthest from farm property.
- 4.5.5. The sketch diagram on this page demonstrates the design intention where the reduced and mitigated visual impact can be initially achieved by strategic siting of plant and buildings and then further assisted by perimeter landscape screening.

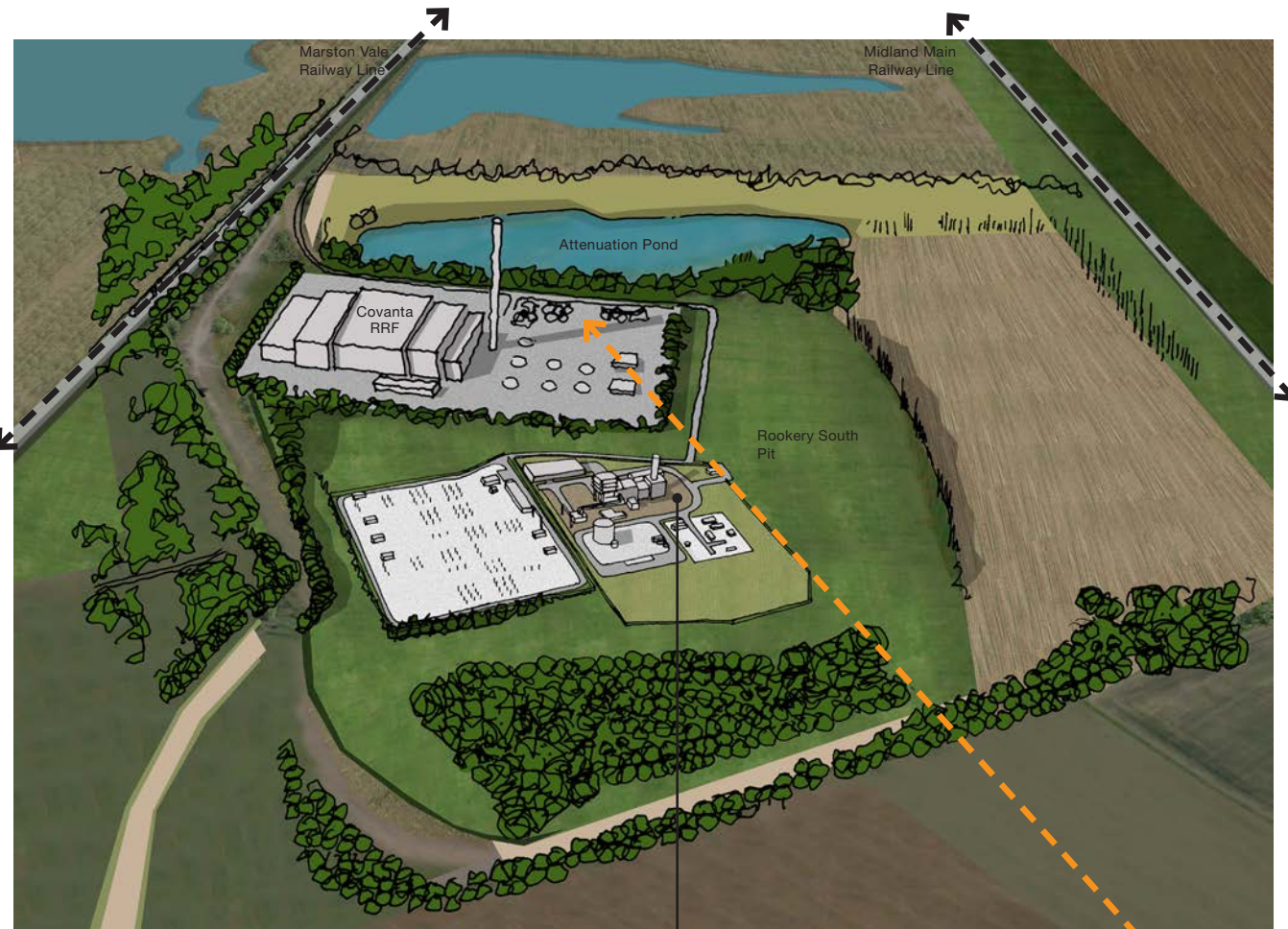

Generating Equipment at ground level within Rookery South Pit set lower than pit embankment thus naturally reducing visual impact from distant views.

View from Amphil Park





- 4.5.6. Centralising plant allows for maximisation of mitigation opportunities (screening) with the use of designed landscaping.
- 4.5.7. Screen planting (hedgerows or woodland) will match and compliment existing species and be integrated to mitigate visual impact on views.
- 4.5.8. The southern edge tree planting will link with the already mature adjacent plantation at the southern edge of the Rookery Pit.

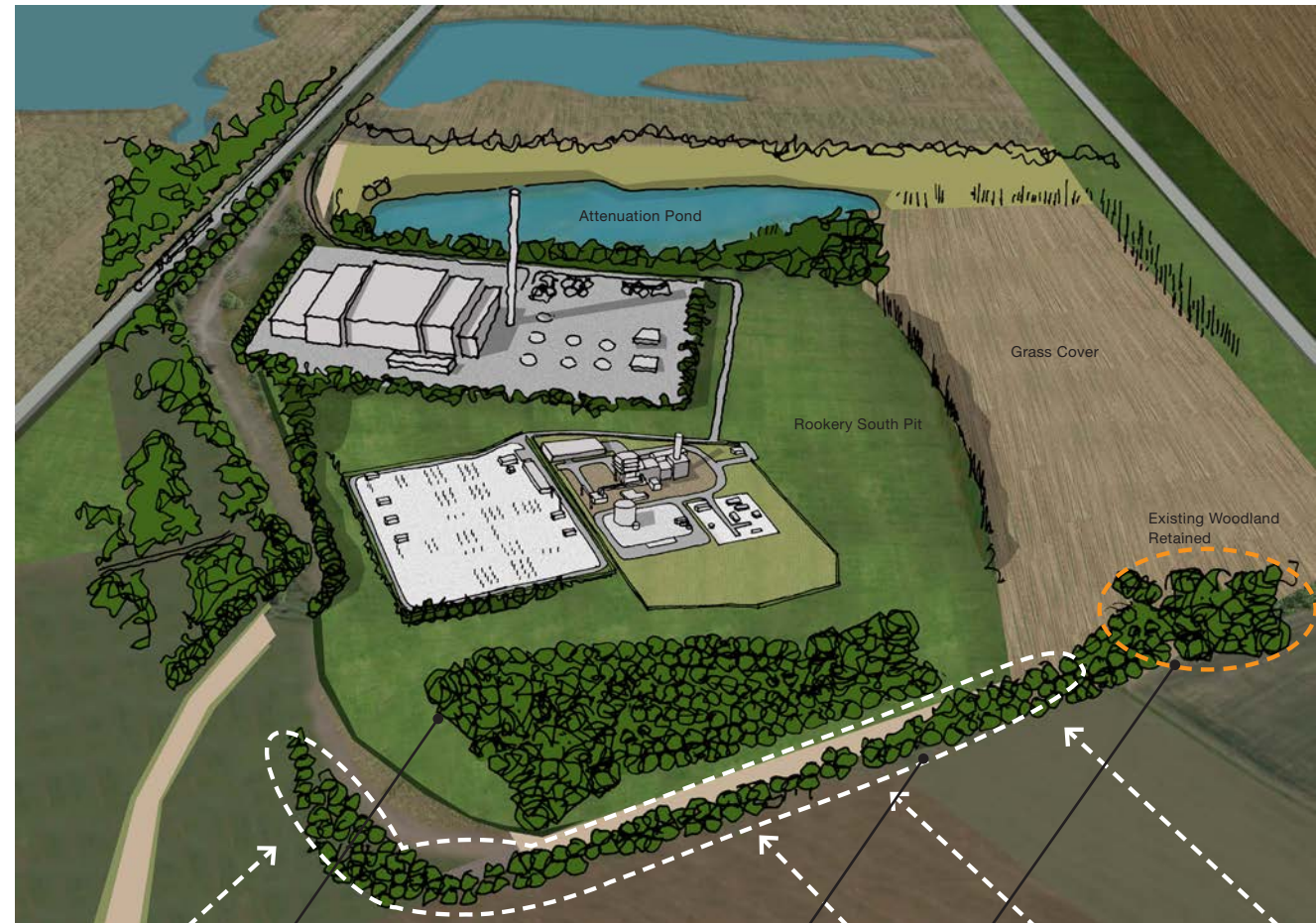

LLRS planting within the Rookery South Pit

Proposed continuous belt of woodland or hedgerows planted along Southern & Eastern edge of pit embankment to minimise visual impact from distant views

Proposed planting to link with existing woodland to create continuous screening





4.5 Design Response : Context

Mature woodland at upper edge of pit

Line of upper edge of pit

Lower ground plane of pit providing a platform for proposed plant and assisting the visual mitigation.

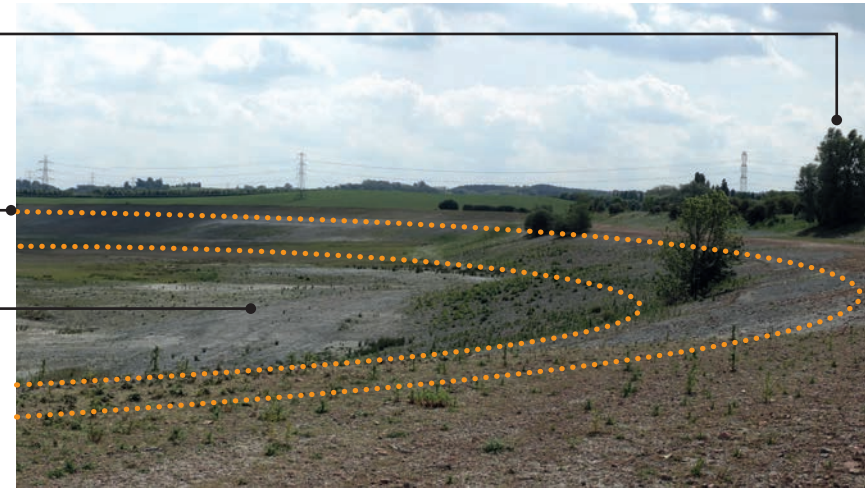

Design landscape integrated with existing mature woodland

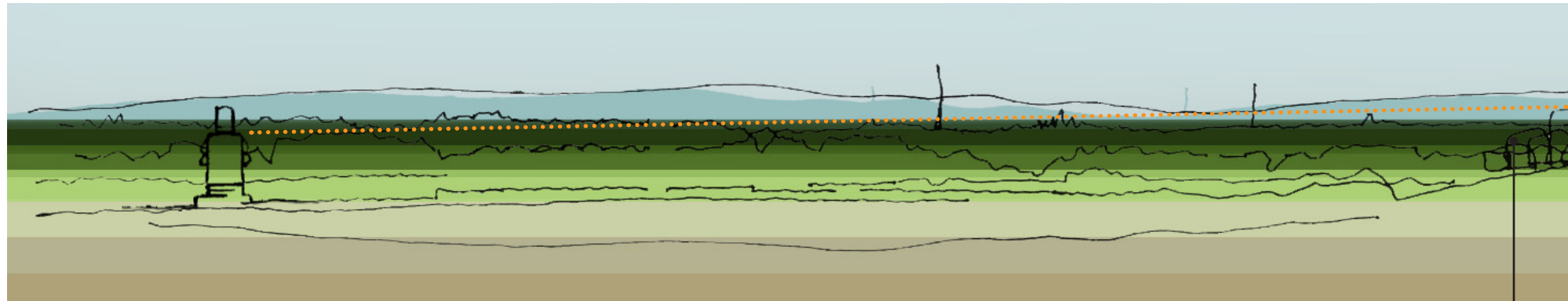



View of skyline from south of the Rookery dominated by brick chimneys at Stewartby

Line of already established mature woodland

Line of upper edge of pit screens lower ground plant within pit

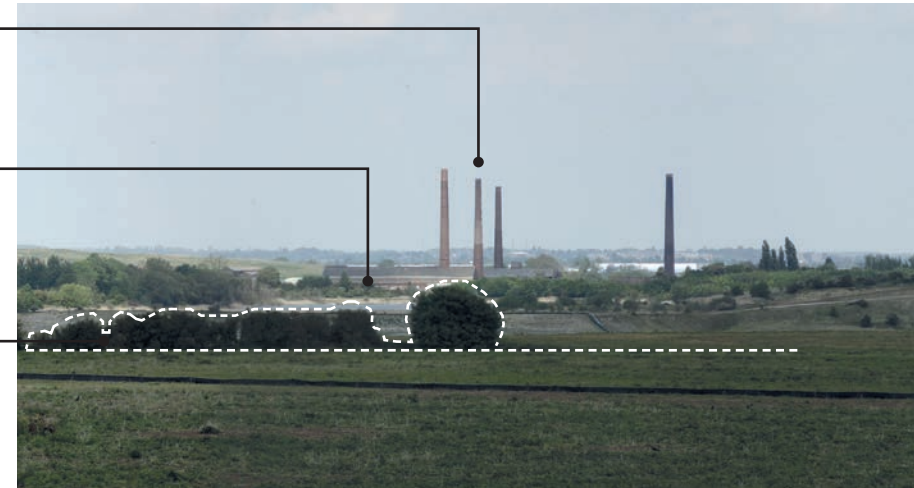

View from Amphill Park

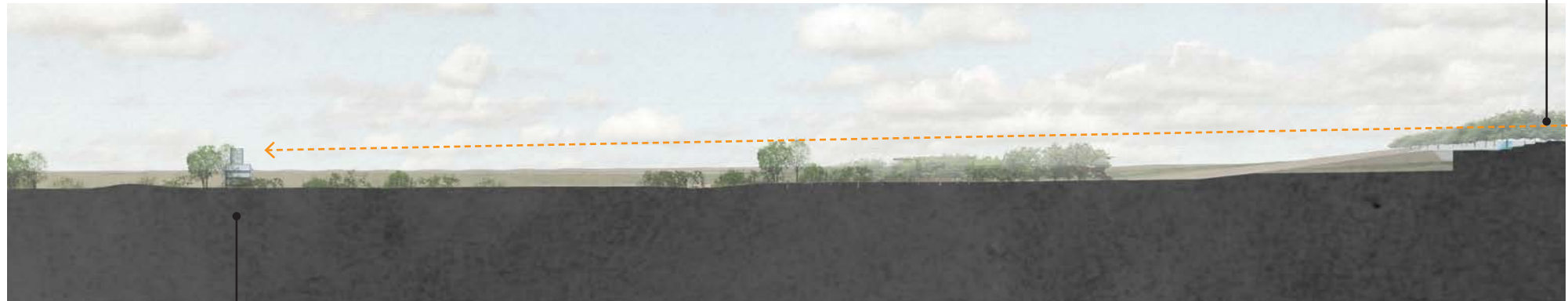

Ground plane within pit lower than banks thus reducing visual impact from distant locations





4.6 Design Response : Proposed Design Approach

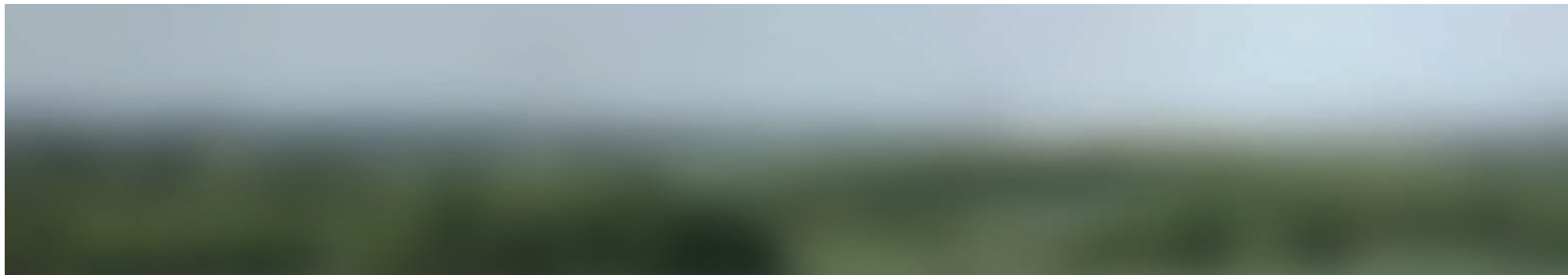
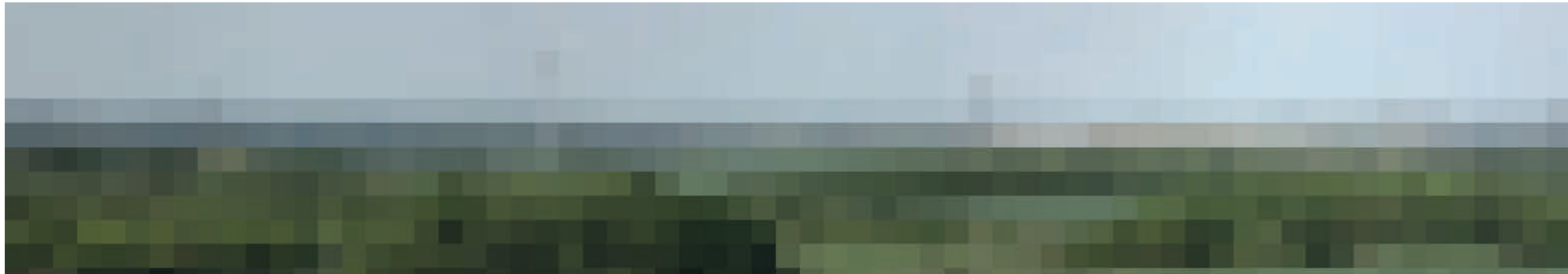

Design Principles

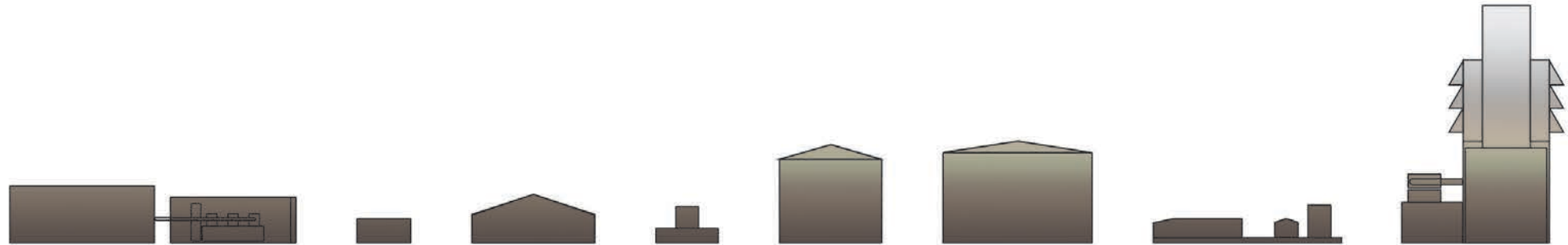
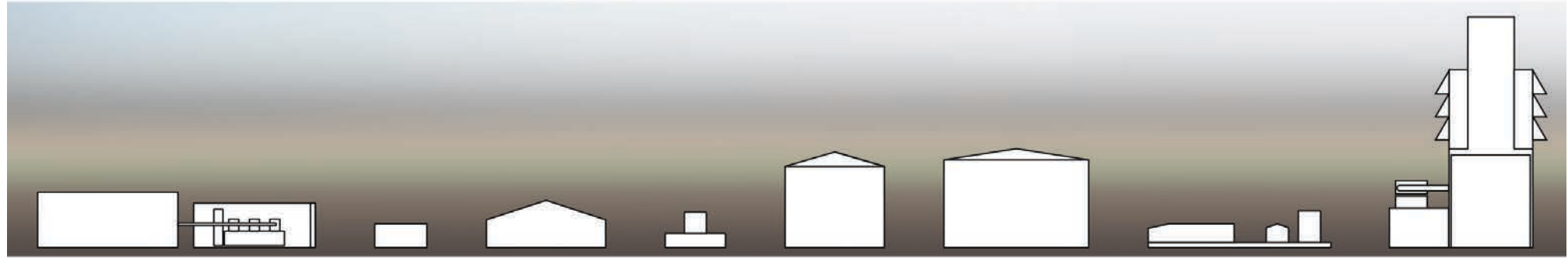



4.7 Design Response : Proposed Design Approach

East Elevation

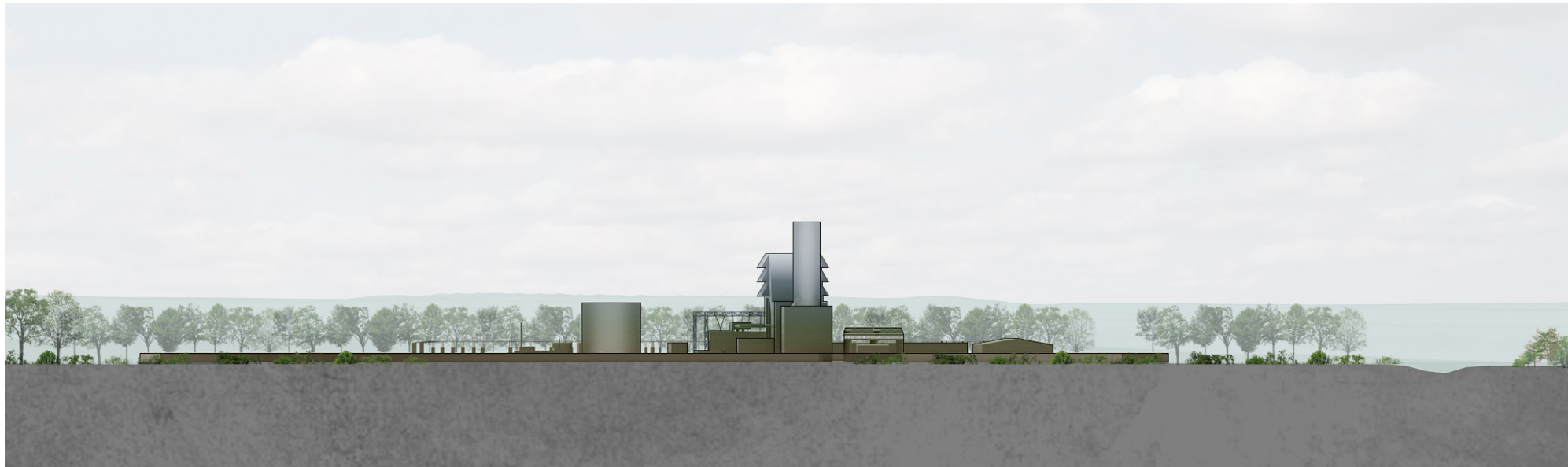



West Elevation

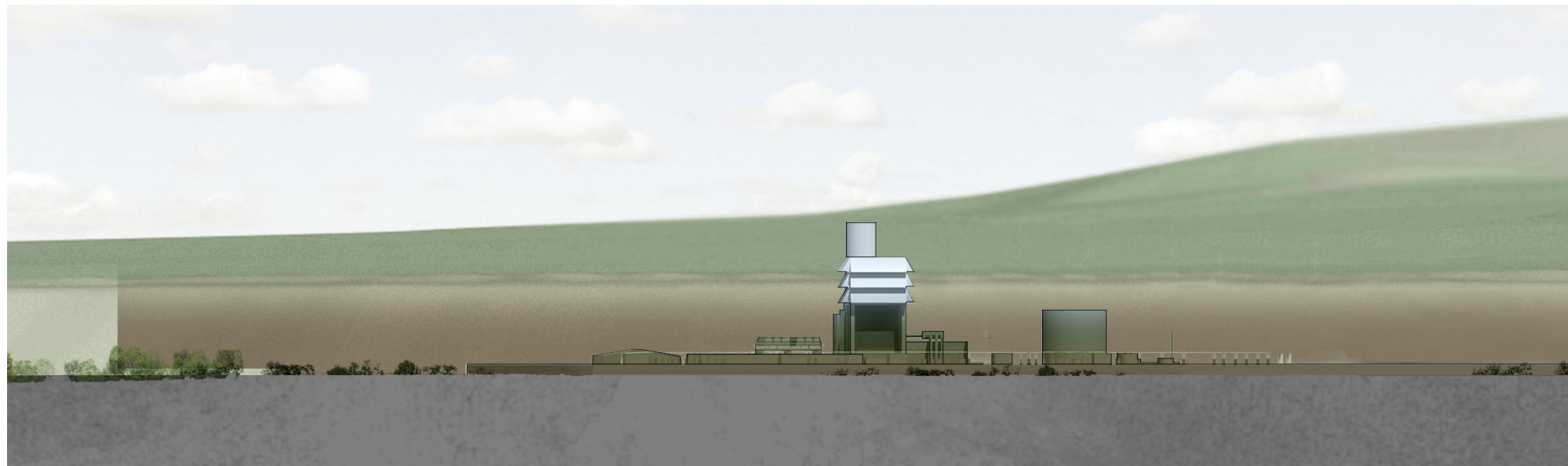



4.8 Indicative Development Proposals : Photomontage





4.8. Indicative Development Proposals : Photomontage





4.8. Indicative Development Proposals : Photomontage

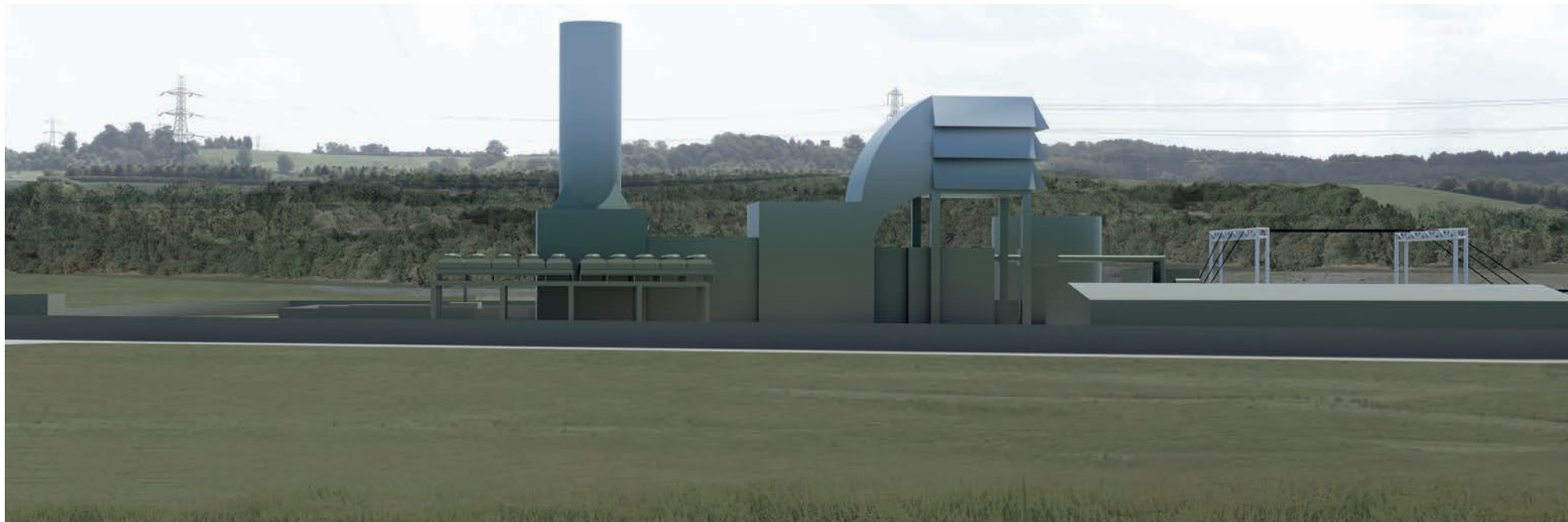

Development proposals





4.8. Indicative Development Proposals : Photomontage



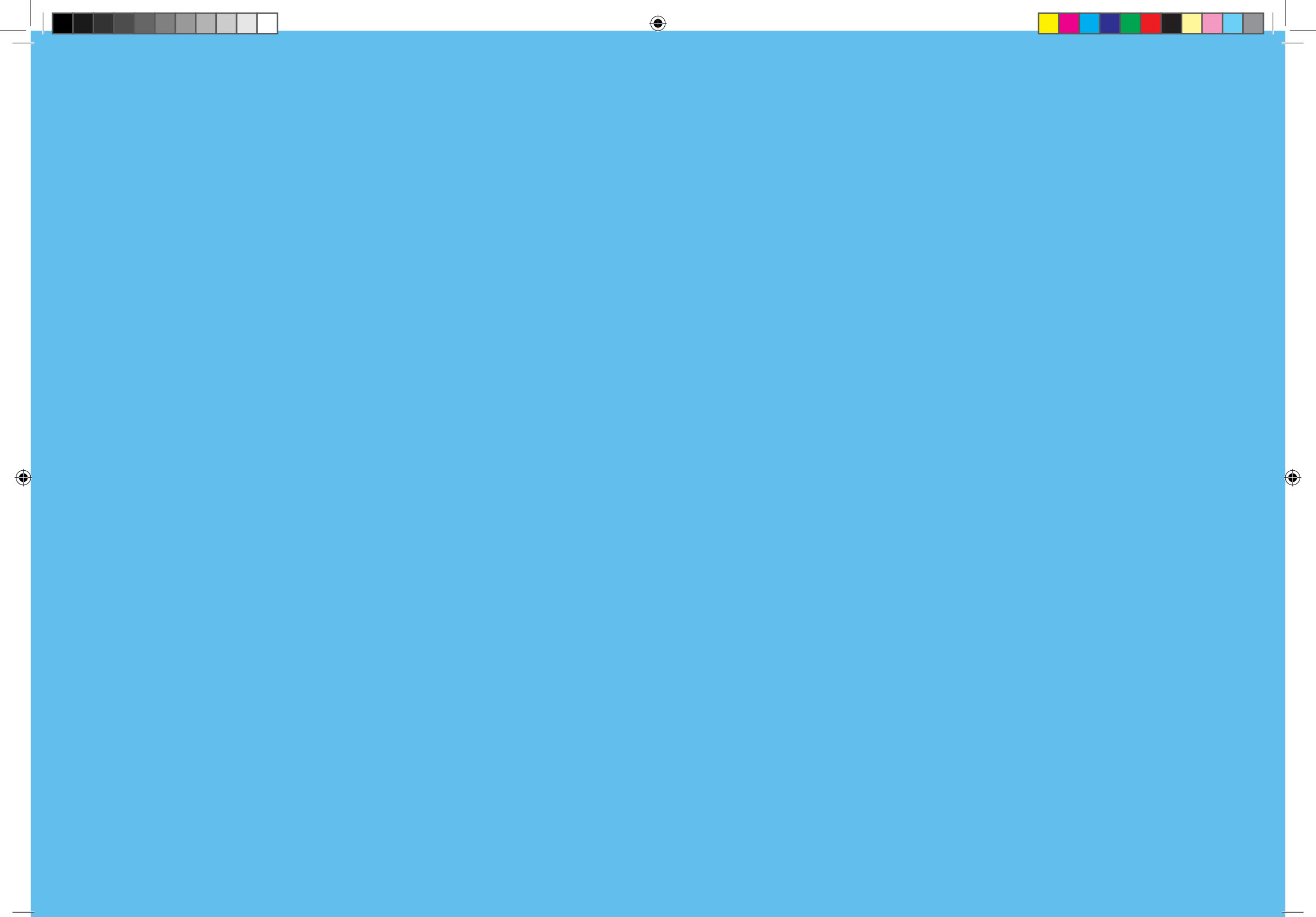



05. Indicative Development Proposals





5.1 Indicative Development Proposals

5.1.1. This chapter describes the Project under the following headings:

5.1.2. **Use and Amount**

What will the building and spaces be used for?
How much will be built on site?

5.1.3. **Layout and Access**

How will the building and spaces be arranged on site, and what is the relationship between them?

5.1.4. Why have the access points and routes been chosen?

5.1.5. How does the Project respond to road layout and public transport provision?

5.1.6. **Scale and Massing**

How big will the Project components be (height, width, length)?

5.1.7. **Landscape and Appearance**

What might the Project components look like? What might the Project appearance be to the public?

5.1.8. **Sustainability**

What are the key principles for energy efficiency and sustainability?

5.1.9. **Use & Amount**

In terms of use and amount, the Project consists of three main elements, as described in Chapter 1. These are:

**Power Generation Plant;
Gas Connection; and
Electrical Connection**

5.1.10. The use and amount of these elements of the Project are described in more detail below:

5.1.11. **Power Generation Plant**

The Power Generation Plant incorporates the Generating Equipment, the Access Road and the Laydown Area.

5.1.12. **Generating Equipment**

The Generating Equipment in the Power Generation Plant comprises a single Gas Turbine Generator. The Gas Turbine Generator consists of gas turbine, generator, air inlet filter house, air inlet duct, exhaust diffuser, and auxiliaries such as lube oil system, air dryers, fuel gas filter package, instrument air system, compressor washing.

5.1.13. Air would be compressed in the compressor of the Gas Turbine Generator and natural gas injected into the combustion chamber where it would burn producing hot, high-pressure gases. These gases would expand across the rotor blades of the gas turbine, which would drive both the compressor and the generator.

5.1.14. The hot exhaust gases would then be routed directly to the stack and emitted to the atmosphere. The stack contains a silencer to reduce noise emissions.

5.1.15. A schematic of the Generating Equipment Site is shown on page 89.

5.1.16. The following ancillary items would also be present at the Generating Equipment Site:

- Raw / Fire Water Tank: The fire water storage tank would be designed to comply with the relevant fire regulations and would be installed together with fire pumps, hose reels, fire hydrants and portable extinguishers;
- Demineralised Water Tank: Required to store demineralised water for the Generating Equipment (used for e.g. blade washing);
- Control Room / office / workshop Building: Required in order to monitor the plant operation and house plant controls;
- Gatehouse: Needed to provide security and maintain a log of site attendance, deliveries etc.;
- Electrical Transformer Compound: Required to connect the electrical infrastructure from the Generating Equipment to transformers before export to the Substation which is part of the NETS, via overhead cables. This would also include a generator step-up transformer, unit and other transformers, an overhead line gantry and associated equipment;



- Natural Gas Receiving Station: Required to ensure that gas coming from the National Transmission System feeds into the Generating Equipment Site at the right flow and pressure conditions. This would include a compression station, emergency generator, Joule-Thompson boilers and auxiliary control cabinets;
- Fin-Fan Coolers to provide cooling to the Generating Equipment;
- Telemetry apparatus including electrical cabinets;
- Emergency Generator: A small diesel fired generator to provide power for the safe shutdown of the Gas Turbine Generator and running of essential security systems in emergency situations; and
- Maintenance Compound: an area of hard standing for use during maintenance procedures.

5.1.17. Laydown Area

A temporary Laydown Area for the storage of plant and equipment during construction would be provided adjacent to the Generating Equipment Site.

5.1.18. Access Road

An agricultural access track is already in existence at the Project Site, linking Green Lane to Rookery South Pit. This access will be upgraded to provide access to the Project. Further detail about the Access Road is provided in 5.3 and 5.4 - Indicative Development Proposals: Layout & Access.





5.2 Indicative Development Proposals : Gas In Electricity Out

5.2.1. Gas Connection

A new underground gas pipeline, approximately 1.8 km in length, is required to connect the Generating Equipment to the existing National Transmission System to provide a reliable supply of fuel. Connection to the National Transmission System would require two above ground facilities to be installed, a minimum off-take connection facility (containing monitoring and control equipment), which would be owned by National Grid Gas, and a Pipeline Inspection Gauge launching facility (required for maintenance operations on the Pipeline) which would be owned by MPL. Together these form the AGI.

5.2.2. The pipeline begins at the AGI which would allow connection into the National Transmission System Feeder 9, east of the Millbrook Proving Ground approximately 1.45km south of the Generating Equipment Site. The Pipeline crosses a farm track which is connected to Lower Farm, National Transmission System Feeder 9, a PROW, drainage ditches, Millbrook Road and then an oil pipeline. The route then turns down into Rookery South Pit before terminating at the Gas Receiving Station within the Generating Equipment Site.

5.2.3. Construction of the Gas Connection would likely take place within a 50m wide strip of land along the Gas Connection route, which would be increased or decreased in size where required (for example, decreased adjacent to nature conservation areas). It is expected that the Pipeline will be constructed using standard open-cut cross-country pipeline

construction techniques (i.e. a trench). Trenchless techniques (e.g. Drilling) may be used in some locations to reduce impacts on sensitive areas or public highways.

5.2.4. Connection to the National Transmission System would require two adjacent above ground facilities to be installed; a Minimum Off-take Connection (MOC) facility, and a PIG Trap Facility (PTF) (these two facilities together are referred to as the AGI). The AGI would contain the following pieces of equipment to allow for the regulation of gas delivery to the Power Generation Plant and to allow monitoring and maintenance.

5.2.5. The MOC would contain:

- Remotely Operable Valve (ROV);
- Control and Instrumentation Kiosk;
- Electrical Supply Kiosk.

5.2.6. The PTF would contain:

- PIG Launching Facility;
- Emergency Control Valve;
- Isolation Valve;
- Control and Instrumentation Kiosk;
- Electrical Supply Kiosk.

5.2.7. Electrical Connection

The Electrical Connection for the Project has been designed to provide the most direct and least environmentally damaging route between the Power Generation Plant and the NETS.

5.2.8. Following statutory consultation, subsequent engagement and technical assessment, MPL considered that there were four potentially viable electrical connection options, including two overhead line and two underground cable options. Statutory consultation generated a number of responses expressing concerns over the potential impacts of the overhead line connection options, which would require new pylons on the landscape, resulting in impacts on visual amenity, and in particular in potential adverse effects on Ampthill Park. During its evaluation of responses, MPL recognised that consultees had expressed a strong preference for the development of an underground cable connection option. These views were taken on board by MPL and a presumption in favour of developing a wholly or partially underground cable option was adopted by the Project team. This was considered to represent more limited potential for significant adverse landscape and visual impacts than an overhead line option. Further information about the iterative process behind the design and layout of the Electrical Connection is described in chapter 5 of the Environmental Statement (Document Reference 6.1).

5.2.9. The Electrical Connection will connect into the existing double circuit 400kV line (forming part of the NETS) which runs from Sundon to Grendon. The 400kV line is located approximately 320m southwest of the Generating Equipment Site. The Electrical Connection will require two SECs, one located on each side of the existing transmission line at the point of connection. Underground cables approximately





500m in length would connect the SECs to the new substation (to be constructed within Rookery South Pit).

5.2.10. Substation

A new 400kV substation to be located in the Rookery South Pit, adjacent to the Generating Equipment Site. A substation can either be an air insulated substation (AIS) or a gas insulated substation (GIS). MPL considers that the Substation with AIS technology is appropriate and acceptable within Rookery South Pit – an AIS substation would be approximately 200m x 150m.

5.2.11. The plans and descriptions on the following pages describe how the Project will be laid out and accessed.

5.2.12. The maximum area for the Generating Equipment Site would be approximately 4ha. It consists of a series of buildings, structures and plant which are all integral to the generation of electricity through combustion of natural gas, as well as areas of hard-standing, internal roads, car parking, landscaping and a laydown area.

KEY

-  Project Site Boundary
-  Gas In
-  Gas Connection
-  Electricity Out
-  Electricity Connection





5.3 Indicative Development Proposals : Access

5.3.1. An agricultural access track is already in existence at the Project Site, linking Green Lane to Rookery South Pit. The Covanta RRF and the LLRS include work to upgrade this track and build a new ramp into the Rookery South Pit. The Covanta RRF includes provision to upgrade the track to a tarmac road suitable for 352 traffic movements a day for the delivery of waste via HGV. Should this road be developed as part of the Covanta RRF prior to the development of the MPL Project, it would be suitable to meet both the needs of the Project and the Covanta RRF. In this instance, there would be a requirement for a short section of new Access Road (the Short Access Road) of approximately 400m in length connecting the end of the Covanta RRF road to the Generating Equipment Site.

5.3.2. However, because it is not certain as to when or if the Covanta RRF will be implemented, MPL has also included the provision of a complete Access Road from Green Lane to the Power Generating Site within this Project. If the Covanta RRF is not built before construction commences for the Project then this complete 2.2km long Access Road would be constructed. The complete Access Road would be constructed from tarmac, bordered by a concrete kerb and be 6m wide to allow for two-way traffic.

5.3.3. The route of the Access Road from Green Lane would follow the alignment of the access road proposed within the LLRS and the Covanta RRF along the existing access track which borders Rookery North Pit. On reaching Rookery South Pit, the Access Road

would use the LLRS access ramp to enter into the pit and cross through the base of the pit until it reaches the Generating Equipment Site.

5.3.4. Two options will be used with regard to access for the Gas Connection during construction. These access options are as follows:

- Through Rookery South Pit, from the Power Generation Plant Site;
- From the A421, northwards along the A5141, westwards then southwards for approximately 7km along the B530 (referred to variously along its route as Ampthill Road / Hardwick Road / Bedford Road / Hazelwood Lane) to Millbrook Road.

5.3.5. An existing junction off Houghton Lane onto an existing agricultural track will be used to access the AGI. This short access track would be upgraded to tarmac top.



Green Lane Looking West



Access track to Rookery South Pit off Green Lane



Green Lane Looking East



5.3 Indicative Development Proposals : Access



- KEY
- Project Site Boundary
 - Road Access Route



5.4 Indicative Development Proposals : Layout

5.4.1. The maximum area for the Generating Equipment Site would be approximately 4 ha. It consists of a series of buildings, structures and plant which are required for the generation of electricity through combustion of natural gas, as well as areas of hardstanding, internal roads, car parking and landscaping.

5.4.2. Each individual component of the Project is necessary for its operation. These components have been sited according to the operational requirements of the Project, whilst having regard for the need to protect the amenity of surrounding uses and ensure visual impact is mitigated and minimised.

5.4.3. The key Project components are set out in the section above and an indicative Project Site layout is shown overleaf. The Project has been laid out to take advantage of the proximity to gas and electricity infrastructure and maximises the use of space within the Power Generation Plant footprint.

5.4.4. The layout and design of the Electrical Connection has gone through a detailed and iterative process, which is described in chapter 5 of the Environmental Statement (Document Reference 6.1). The chapter details the options for the connection between the Substation and the NETS, along with the justification for ruling them out and for the selection of the underground cable option.

5.4.5. The electrical transformer is located at the western end of the Power Generation Plant, closest to the 400kV NETS, in order to limit the length of electrical

cable across the Power Generation Plant footprint. Furthermore, MPL have elected to progress an underground cable option for connection between the Substation and the existing 400kV overhead line in response to feedback received during statutory consultation. By undergrounding the cable, the potential impacts of the Project on visual amenity will be minimised.

5.4.6. Similarly, the gas infrastructure is located in the south of the Project Site to limit the amount of excavation for the gas pipeline.

5.4.7. The Gas Turbine Generator is located in the east of the Power Generation Plant Site, in order to be as far away as possible from the nearest residential receptor.

5.4.8. The Power Generation Plant Site has also been laid out to provide a safe working environment and to allow sufficient space for maintenance.

5.4.9. Although the Project represents industrial development, and the design and layout are in line with relevant safety standards, MPL has sought to mitigate impacts on the countryside as much as possible by, e.g., careful landscape planting and undergrounding of the electrical cable.

5.4.10. The layout and landscaping plans seek to limit visual impact and reduce impact on farming operations.



5.4 Indicative Development Proposals : Layout



KEY

- • • Project Site Boundary
- ① 400kV Substation
- ② Control Room / Office / Workshop
- ③ Gate House
- ④ Transformer
- ⑤ Raw/ Fire Water Tank
- ⑥ Demineralised Water Tank
- ⑦ Emergency Generator
- ⑧ Diesel Tank
- ⑨ Natural Gas Receiving Station
- ⑩ Stack
- ⑪ Gas Turbine Generator
- ⑫ Fin Fan Cooler(s)
- ⑬ Site Fence
- ⑭ Substation Auxilliary Building
- ⑮ Tanker Unloading Station
- ⑯ Site Access
- ⑰ OEM Maintenance Area



5.5 Indicative Development Proposals : Scale & Massing

5.5.1. The plan overleaf and the following drawings illustrate the scale and massing of the main Project components.

5.5.2. In order to reduce the mass of the Generating Equipment, it was decided that a single Gas Turbine Generator would replace up to 5 Gas Turbine Generators. The Gas Turbine Generator will be contained within its own acoustic enclosure which will limit noise emissions.

5.5.3. This helps to lessen both the bulk and mass of the Generating Equipment and minimise its visual impact from key viewpoints.

5.5.4. The tallest component(s) of the Power Generation Plant is the Stack. The height has been determined as a result of air dispersion modelling at 32.5m – 35m.

5.5.5. Similarly the air insulation switchgear (AIS) Substation was selected as the most appropriate design option given the 'openness' of the structure and the spaces and gaps between the switchgear and insulators, which help to minimise the mass of the structure and provide views through to the surrounding landscape, rather than of one large structure.

5.5.6. The design of the Project is commensurate with its intended use. The Gas Turbine Generator will be a single unit and will not be sited within a large building, but will be left as individual unit within an acoustic enclosure. This will limit the overall 'mass' of the Power Generation Plant, and will provide a less dense appearance when viewed from outside of the Power Generation Plant Site.

5.5.7. Enclosing the unit within its own acoustic enclosure will limit noise and vibration.

Development proposals



05. Indicative Development Proposals : Site Components



KEY

- . . . Project Site Boundary
- 400kV Substation
- Control Room / Office / Workshop
- Gate House
- Transformer
- Raw/ Fire Water Tank
- Demineralised Water Tank
- Emergency Generator
- Diesel Tank
- Natural Gas Receiving Station
- Stack
- Gas Turbine Generator
- Fin Fan Cooler(s)
- Site Fence
- Substation Auxilliary Building
- Tanker Unloading Station
- ▲ Site Access
- OEM Maintenance Area





5.6 Indicative Development Proposals : Sealing End Compound







5.6.1. Electrical Connection

The Electrical Connection will export power from the Generating Equipment to the NETS. It includes a Substation, two electrical circuits and up to two SECs to connect the Substation to the Generating Equipment and the existing 400 kV network.

5.6.2. Any existing woodland lost to Electrical Connection work will be replanted with appropriate native species.



KEY

-  Project Site Boundary
-  Sealing End Compound
-  Electricity Out
-  Electricity Connection
-  Gas In
-  Gas Connection





PROPOSED SECS
& RELOCATION OF TRANSMISSION TOWER

PROPOSED POWER
GENERATION PLANT

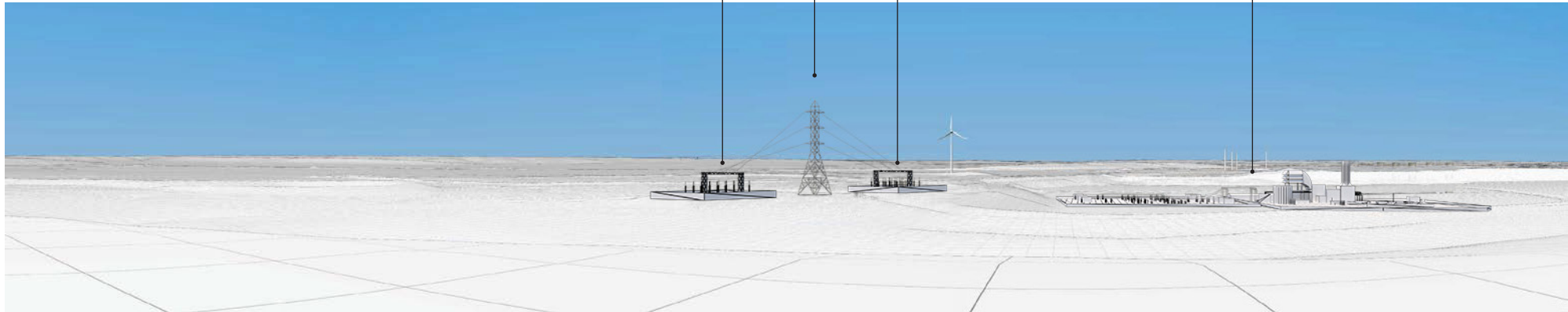

PROPOSED SECS
& RELOCATION OF TRANSMISSION TOWER

PROPOSED POWER
GENERATION PLANT



5.7 Indicative Development Proposals : Landscaping & Appearance

Millbrook Project only scenario (without Covanta RRF)

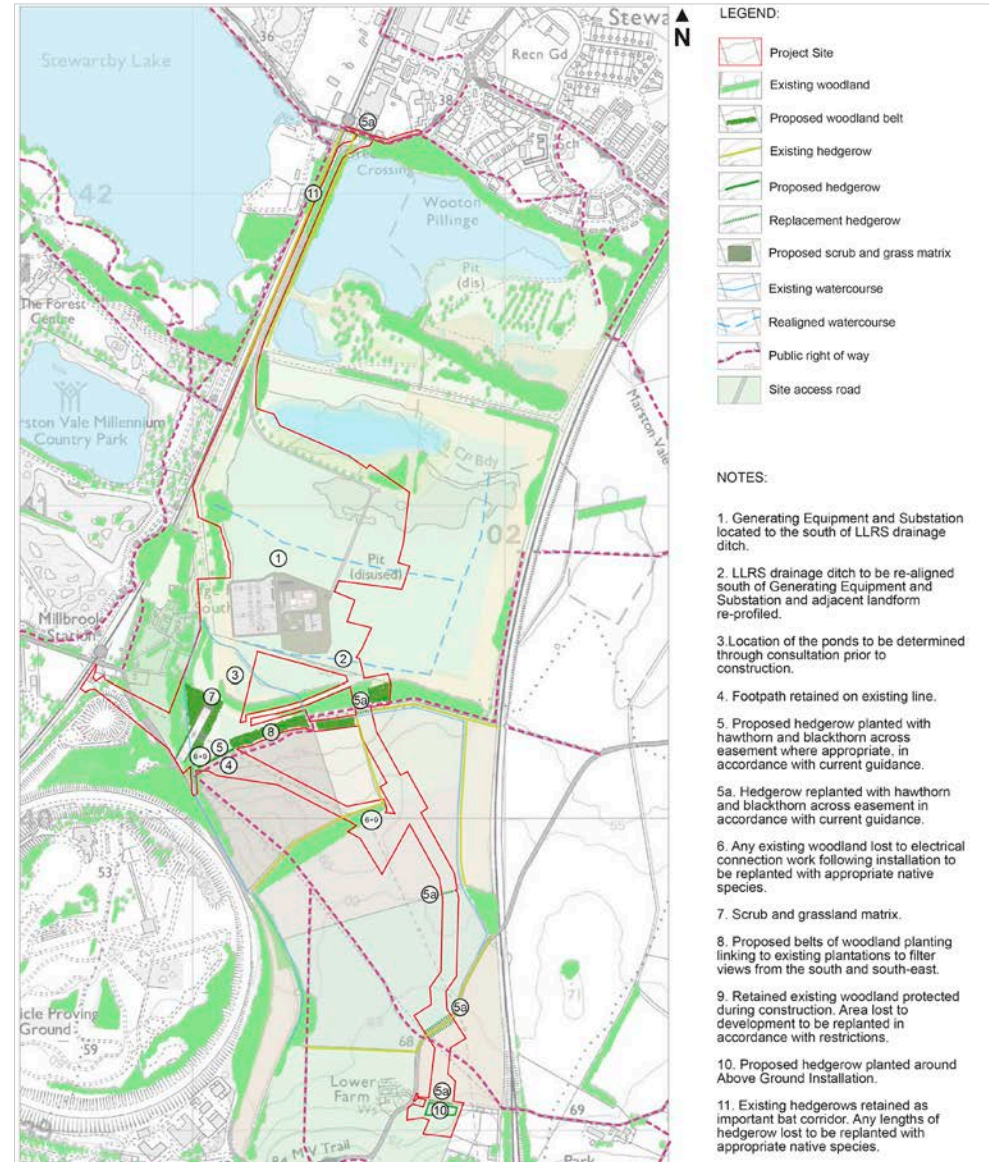



- 5.7.1. The LEMMS includes the creation of a new structurally diverse and species-rich belt of woodland planting, to reflect the species composition within the wider Marston Vale Forest.
- 5.7.2. Management of existing blocks of planted woodland would be expected to enhance their nature conservation value. Native species of local provenance will be used, wherever possible. These new areas of planting linking existing habitats would be expected to increase the connectivity of the Project Site for wildlife. The planting proposed has been designed to ensure the value for biodiversity is maximised, whilst performing a landscape screening and integration function.



5.7 Indicative Development Proposals : Landscaping & Appearance

Millbrook Project and the Covanta RRF

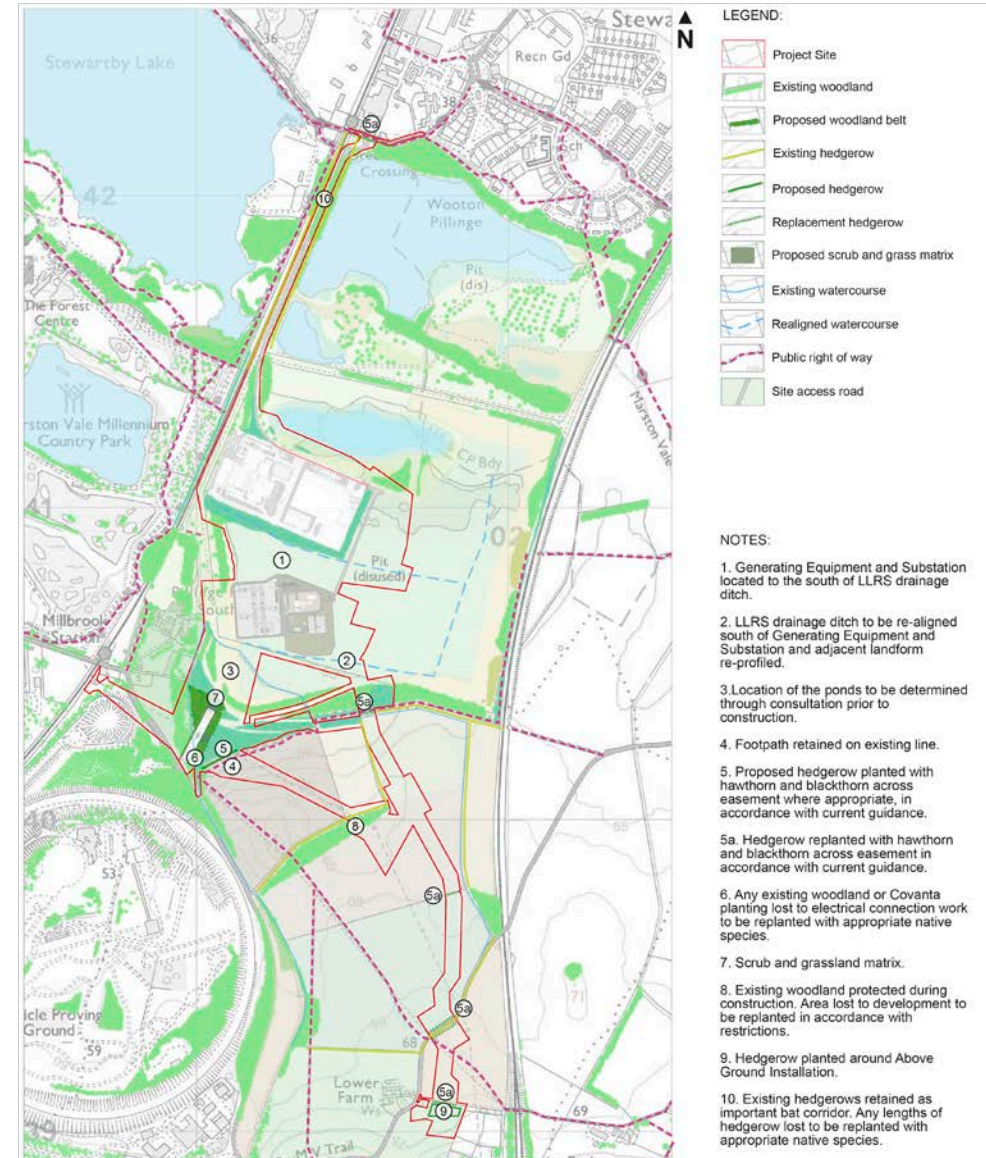



5.7.3. Should the Covanta RRF be constructed, a separate proposal for a LEMMS has been developed which specifically considers the proposals put forward for landscape and ecology mitigation as a result of construction of the Covanta RRF alongside the Project.

5.7.4. Where the Project would result in the loss of mitigation put forward as part of the Covanta RRF, provision has been made to offset this loss with equivalent planting and habitat creation of the same volume with the same or similar species mixes. The outline LEMMS for the Project (should Covanta RRF proceed) has been designed to integrate with the planting proposals for the Covanta RRF by using complimentary species mixes, having regard to any particularly sensitive areas of mitigation proposed, and enhancing existing planting and filling gaps where appropriate. This will ensure that the required level of mitigation for the Project and the Covanta RRF can be met simultaneously and exist together, delivering adequate and appropriate screening, and ecological enhancement for both projects.





5.8 Indicative Development Proposals : Site Sections



Millbrook Power

Covanta RRF



Development proposals





Millbrook Power

Covanta RRF





5.9 Indicative Development Proposals : Visual Impact

Millbrook Project and the Covanta RRF



Development proposals





5.10 Development Proposals : Sustainability

5.10.1. The Project is a 299MW gas fired peaking plant, which will provide enough energy, at times of peak demand, to power the equivalent of up to 400,000 homes.

5.10.2. The Project represents a significant capital investment (in the order of £100M) and will provide up to 150 jobs during construction.

5.10.3. There is a clear need for such plant, as identified in latest government policy, the key elements of which are set out in chapter 1 of this statement.

5.10.4. The Project would not only provide energy at times of peak demand, but would also support intermittent forms of renewable energy (e.g. wind and solar) at times when they are unable to generate electricity. As such, the Project supports the UK Government's drive towards a low carbon economy.

5.10.5. The site selection process for the Project has taken account of the proximity to available gas and electrical connection infrastructure in order to minimise the Project footprint as much as possible and limit environmental impacts associated with the connections.

5.10.6. The Power Generation Plant will be entirely situated within a disused clay excavation pit. There is also an existing consent relating to the site adjacent to the Project Site for the Covanta RRF development. Directing development to a site such as this steers development away from the best quality and most valuable greenfield land and minimizes environmental impacts.

5.10.7. The Project is also entirely situated within an area deemed not to be at risk from flooding, even taking into consideration future predictions of climate change.

5.10.8. The Power Generation Plant will be constructed from high quality materials which will be designed to blend in with its surroundings and the other consented development and LLRS at Rookery South Pit. The materials will be designed to withstand the wear and tear of at least 25 years of operation.

5.10.9. As far as is reasonably practical, the Project will use materials which can be disposed of sustainably (e.g. easily re-usable or recyclable) when the plant has reached the end of its operational life.

Development proposals



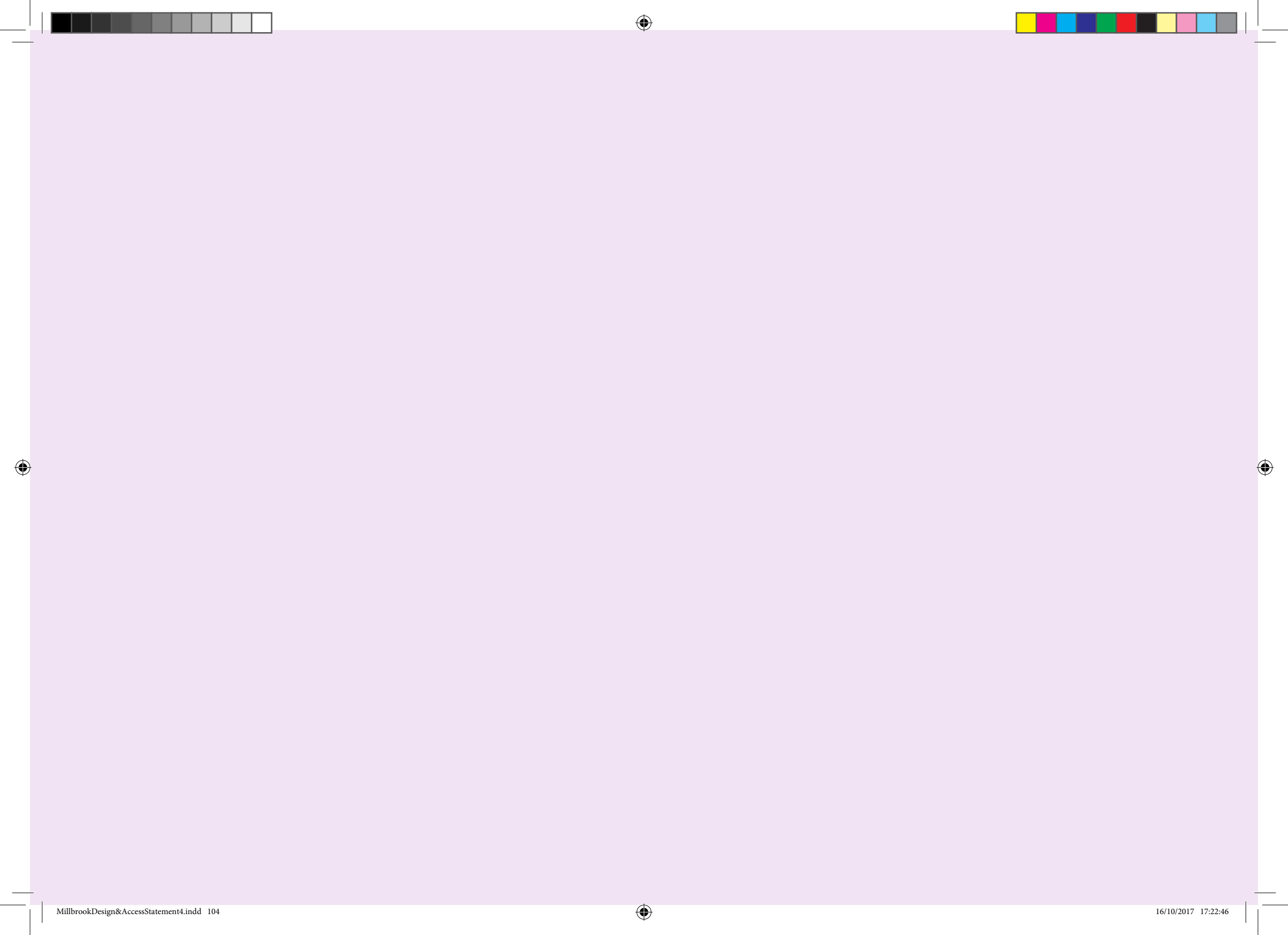



06. Summary & Conclusions





06. Summary & Conclusions

6.1.1. MPL is promoting a new thermal generating station on land at the former clay pits near Millbrook, Central Bedfordshire.

6.1.2. The Power Generation Plant would operate as an Open Cycle Gas Turbine (OCGT) peaking plant could run up to a maximum of 2,250 hours in any given year, provided that the 5 year rolling average does not exceed 1,500 hours. It would be designed to provide a rated electrical output of up to 299 Megawatts (MW) at times of peak demand. The plant would be fuelled by natural gas.

6.1.3. The strategic need for the Project is outlined in various government policies and strategies including, amongst others: National Policy Statements, the Annual Energy Statement (latest version published by DECC, October 2014), the Electricity Market Reform White Paper – Planning our electric future (DECC, 2011), the National Infrastructure Plan (HM Treasury, December 2014), and the report published in October 2016 by The Energy and Climate Change Committee entitled The energy revolution and future challenges for UK energy and climate change policy – Third Report of Session 2016–17. Further details are provided within the Planning Statement (Document Reference 10.1) accompanying the Application.

6.1.4. The Project contains a number of key features which support the proposed use and minimise environmental impact. These include:

- Close proximity to gas and electrical infrastructure and a well developed road network.
- Easily accessible site.
- Not in immediate proximity to residential centres.
- The Power Generation Plant is to be sited within a disused clay pit.
- Close proximity to other similar industrial developments.

6.1.5. In terms of design, the Project is commensurate with its intended use. The form, scale, massing and landscaping has been designed so that the Power Generation Plant blends in with its surroundings as much as possible.

6.1.6. To help limit it's visual impact in long views including from higher ground, it was decided that the Gas Turbine Generator would be contained within its own acoustic enclosure.

6.1.7. The layout has been conceived to use the Project Site in the most efficient way, by locating plant items in close proximity to connections (gas and electrical) and by locating the Power Generation Plant to benefit from the maximum screening effects.

6.1.8. The Power Generation Plant, Gas and Electrical Connections have been designed to limit massing and provide broken views through the main development components to the landscape beyond, rather than creating massive structures.

6.1.9. The Generating Equipment and the Substation will be constructed from high quality materials which will blend in with the proposed development in Rookery South Pit.

6.1.10. The main plant components have been selected to be durable and suitable for their intended use throughout the proposed 25 year lifetime of the Project.

6.1.11. The Electrical Connection for the Project has been designed to provide the most direct and least environmentally damaging route between the Generating Equipment and the NETS. Furthermore, MPL have elected to underground the cable connecting the two, greatly reducing any visual impacts associated with the Electrical Connection.





6.1.12. Key design principles have been followed through from Section 3 of this Statement into a set of design responses which have been described in detail in Section 4. Some of these key design responses include

- Site plan arrangement of the various plant components to minimise any visual impact.
- Introduction of planted trees/hedgerows/shrubs linking with the already established mature planting.
- Colour strategy on various plant components reflecting surrounding near and distant landscape.

6.1.13. In conclusion, this statement supports the approval of the Project.





© Millbrook Power Limited
Drax Power Station
Selby
North Yorkshire
YO8 8PH

<http://www.millbrookpower.co.uk/>

T: 0131 550 3380
E: info@millbrookpower.co.uk